

Manual - ValkScreenVision 2.0

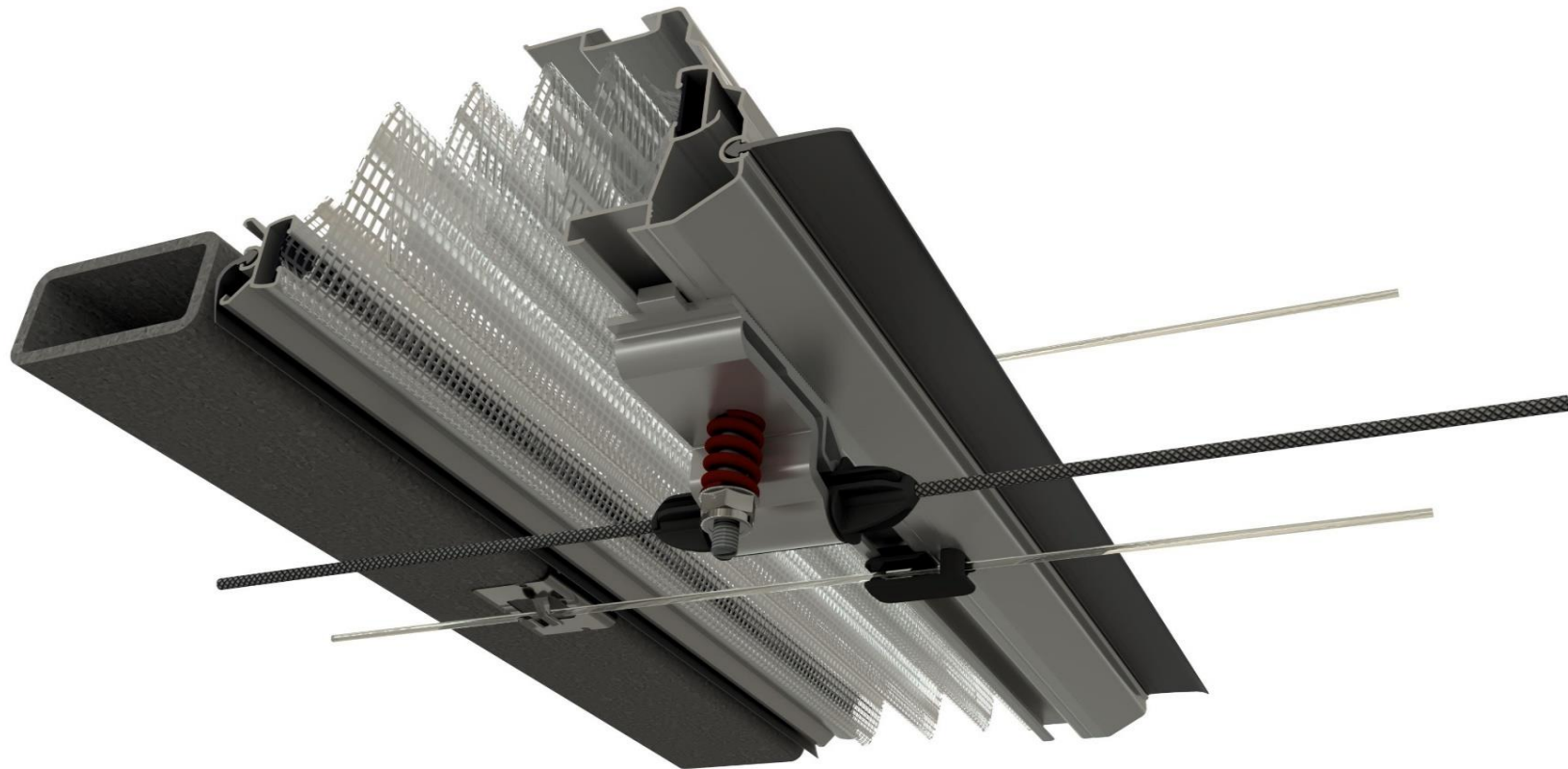

Upper Screen

		page
Table of contents		1
Disclaimer		2
Mounting gable components	Screen plates (55mm)	A1 - 3
ValkReversingWheel section separation	ValkReversingWheel - 2 per trellis	B1 - 3
Mounting ValkBearingBracket	ValkBearingBracket 2.0 - Bearing plate on floating gutter	C1 - 4
Mounting ValkDriveTube	ValkDriveTube X-Reduced	D1
Mounting ValkScreenProfile	ValkScreenVision 2.0 profile	E1 - 2
Measure row ValkTrussClips	VSV 2.0 ValkTrussClips	F1
Polyester wires	Polyester wires to screen plate - With black coated steel wire	G1 - 2
Pull wire	Pull wire	H1 - 4
Return wire pulley (ValkPulley)	ValkPulley attached to VSV screen profile	I1
ValkTrussClips	VSV 2.0 ValkTrussClips	J1
Screen cloth pull rope	Screen cloth pull rope for VSV 2.0	K1
ValkKliMaxSlide (Moved to chapter P)	N/A	L1
Coupling ValkScreenProfiles	VSV 2.0 profile	M1 - 4
ValkWireGuide	ValkScreenVision	N1
ValkScreenClip	N/A	O1
ValkKliMax	VSV	P1 - 2
Retraction of screen cloth	VSV 2.0	Q1 - 3
Screen cloth hangdown	Cloth hangdown - VSV 2.0	R1 - 5

You have chosen a screen system from Van der Valk horti systems. This manual is a standard manual for specific installation drawings, see project drawings and quotation supplied separately. If you see a QR code in the manual, a movie is available with additional explanation. You can watch this movie by scanning the QR code.

- * This manual is not project specific.
- * This manual is not legally binding.
- * No right may be derived from this installation manual.
- * Consult the cloth and motor supplier manual for installation of their products.
- * The order of installation in this manual is carefully chosen, but could differ depending on the installation tools used.



if you scan or click this QR-code you will be linked to the youtube playlist of all installation movies. you will find a specific QR-code at the page.

▶ Mounting screen plate

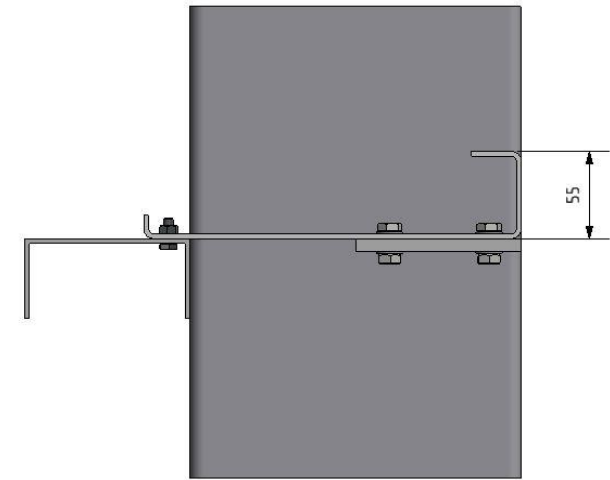
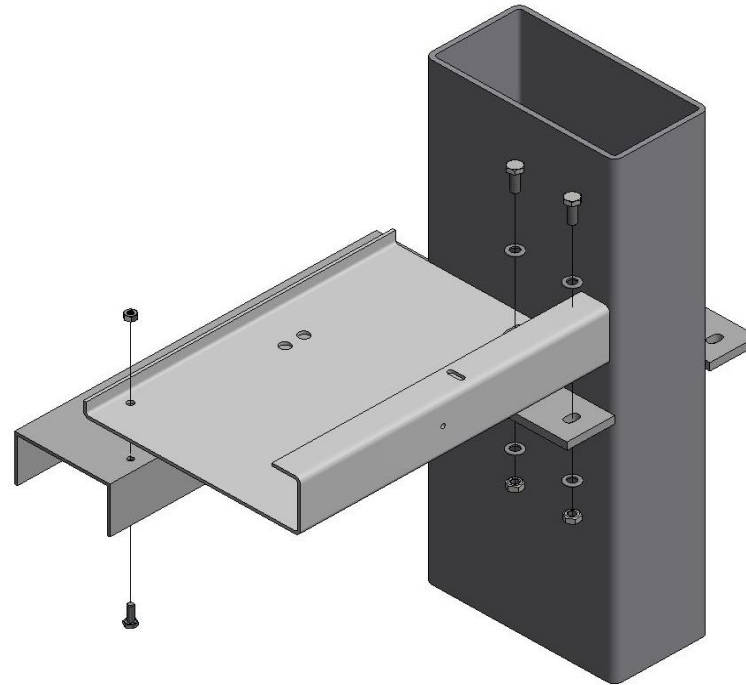
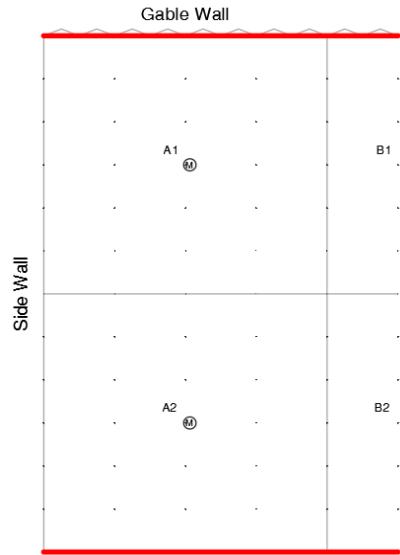

Note: The top of the screen strip is equal to the bottom of the trellis top chord.

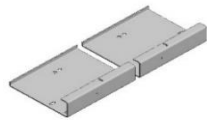

50.7-.055.----



55.40.20 M8x20



55.40.05 M8



53.55.17 M8



55.30.16 M6x16



55.30.00 M6

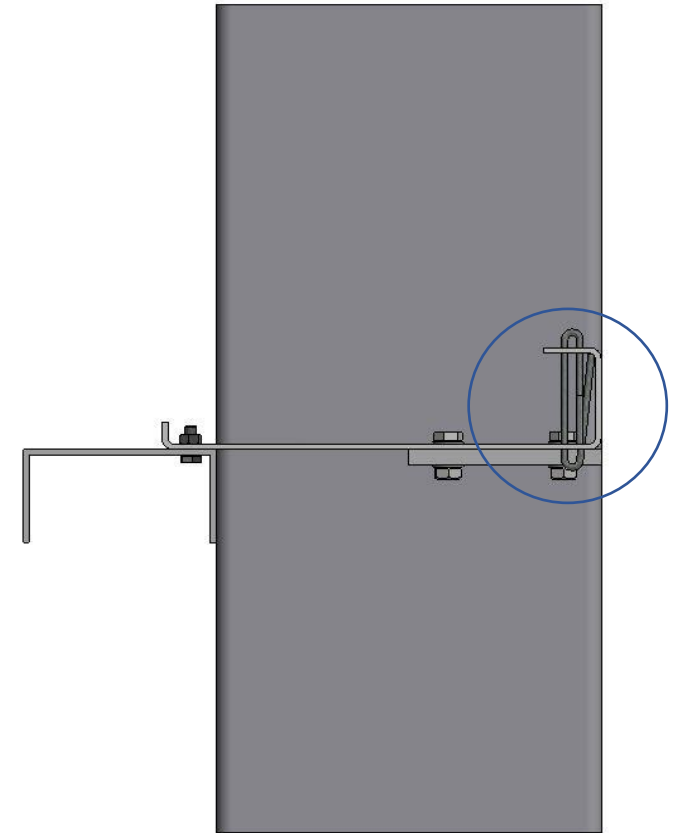
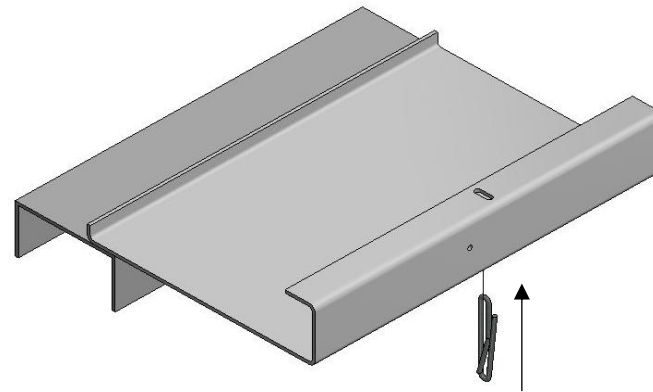
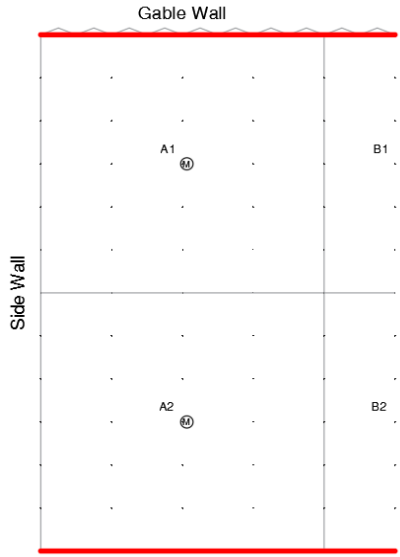

45.81.85

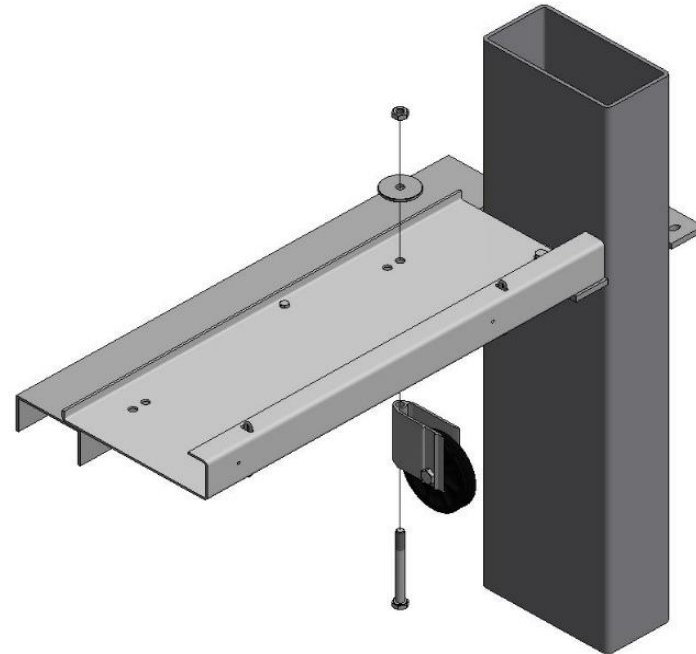
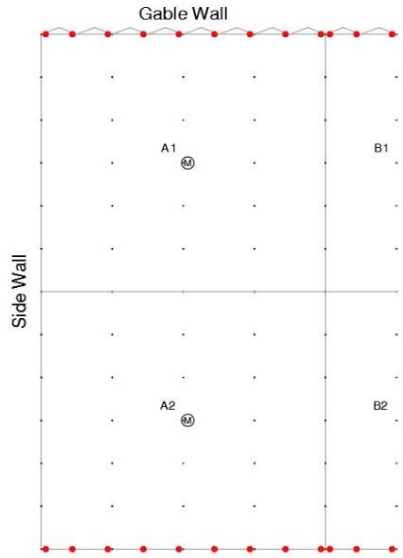

The screen plates are produced with 2 holes for the reversing wheels. Use 1 of the 2 holes.

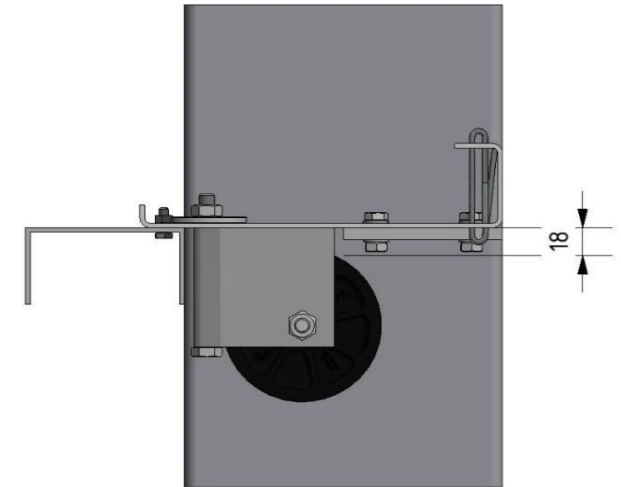

Note: When using the wire clip, the distance between the bottom of the screen plate and the pull wire is 18 mm.



44.81.30



55.51.00 M10x100



53.55.42 M10



55.50.00 M10

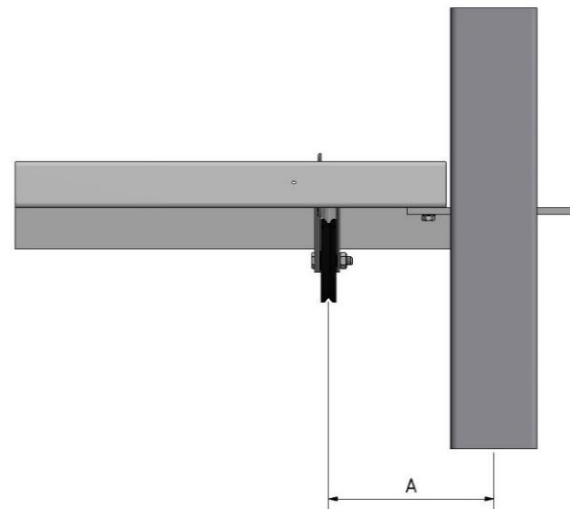

For size A, see project specific file.

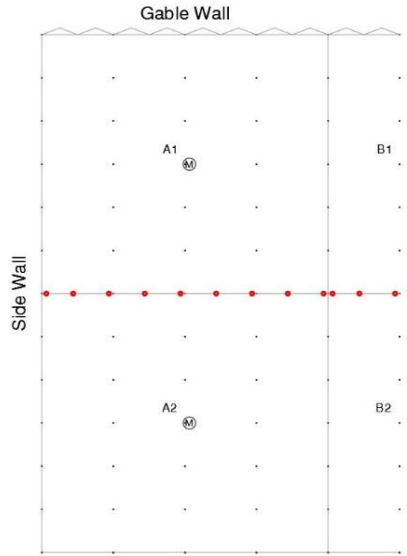

Mount the bolt heads on the package side of the screen.

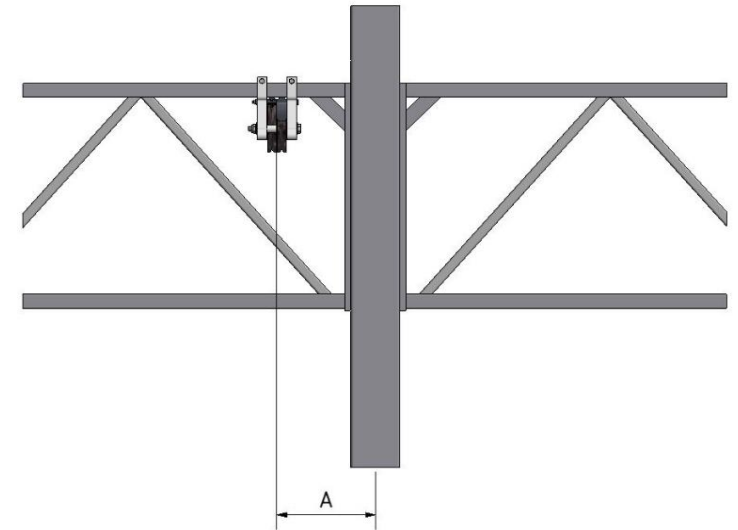
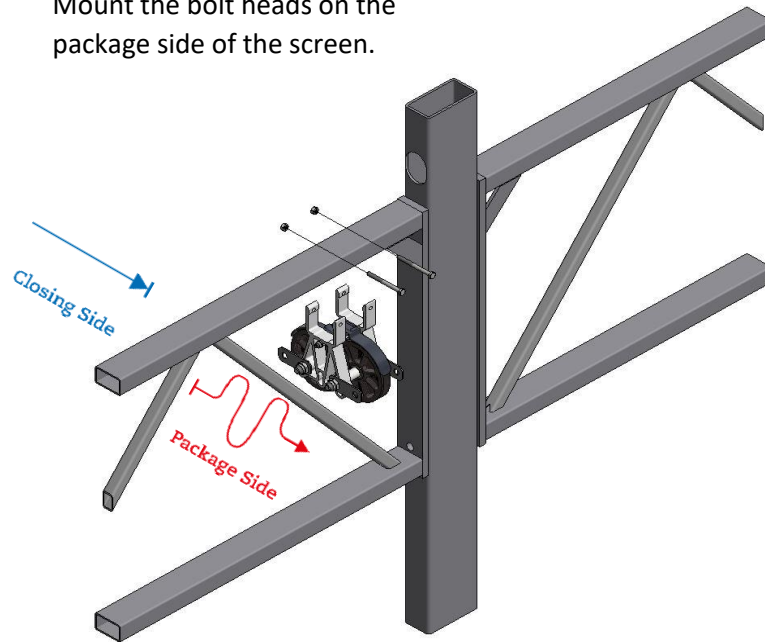

For size A, see project specific file.



(topcord width and height)
44.740.---.---

black



(topcord width and height)
44.750.---.---

gray



(trellis width + 15 mm)
55.30.--

55.30.00

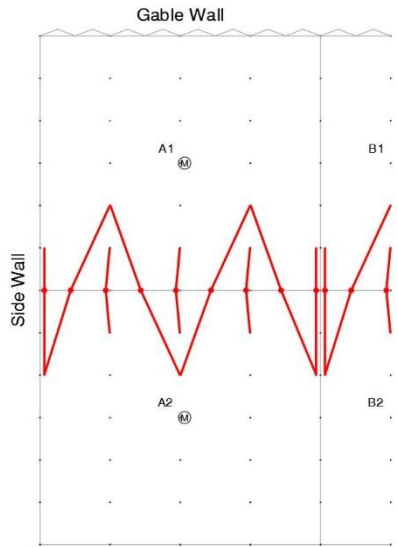

Bracing at the column:

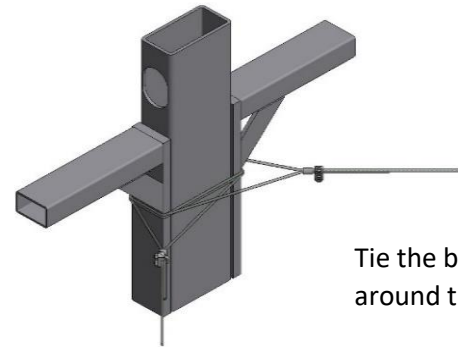

Tie the bracing wire around the column.

Brace diagonally when the reversing wheel is close to the middle of the trellis.

Brace straight when the reversing wheel is close to the column.

Floating gutter:

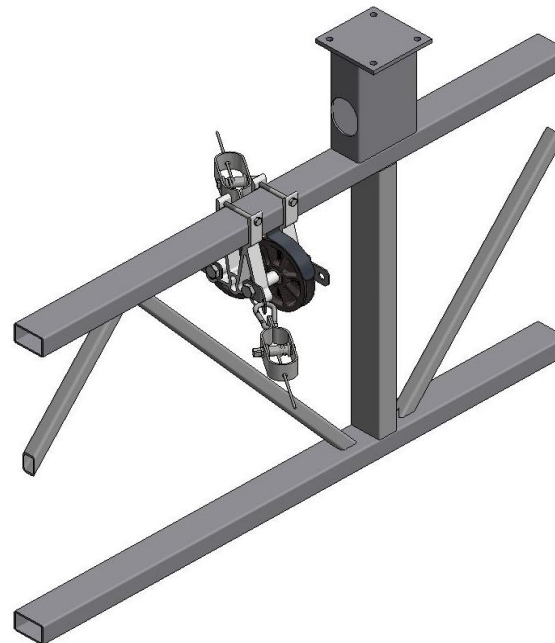

Column.

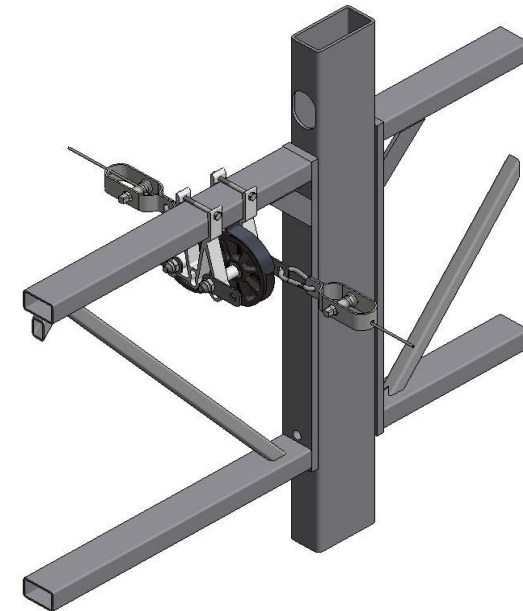

48.10.17



48.80.40



48.80.12



48.80.30



48.80.37

▶ Bracing of ValkReversingWheel at section ends

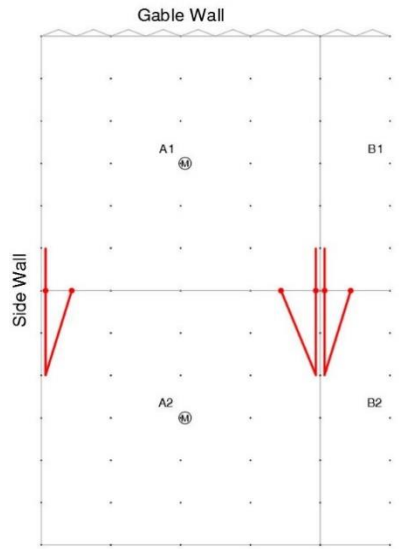

Mount the bearing plate opposite to the pulling side of the bracing wire.

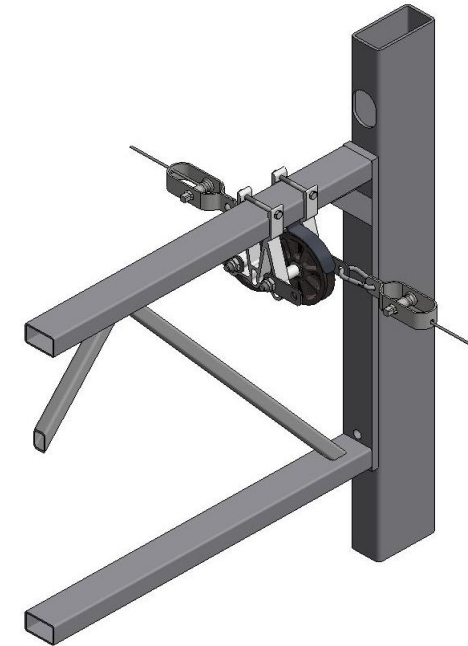
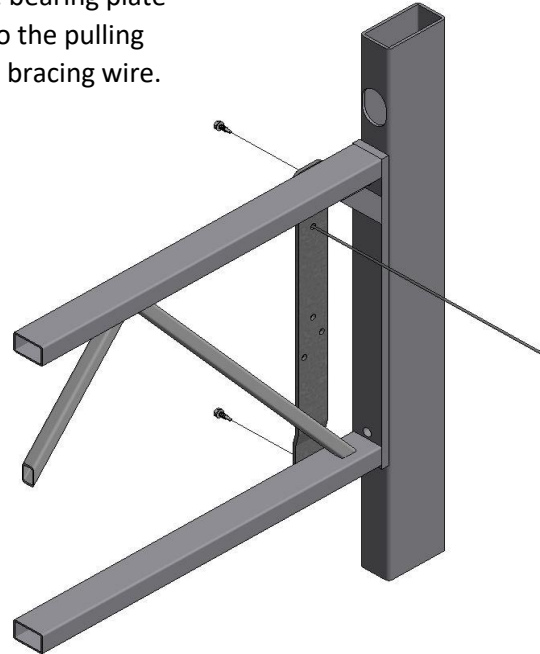

(trellis height)
44.82.10.-----



53.57.20

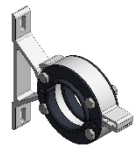
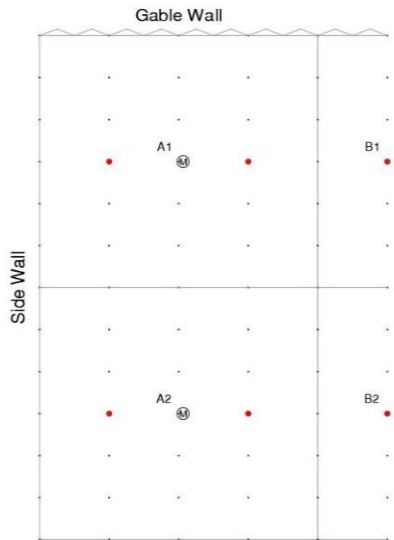

44.82.16



(column width + 20 mm)
55.40.-- M8x---



55.40.00 M8



53.55.17 M8

Drill holes $\varnothing 9$ mm in the column.

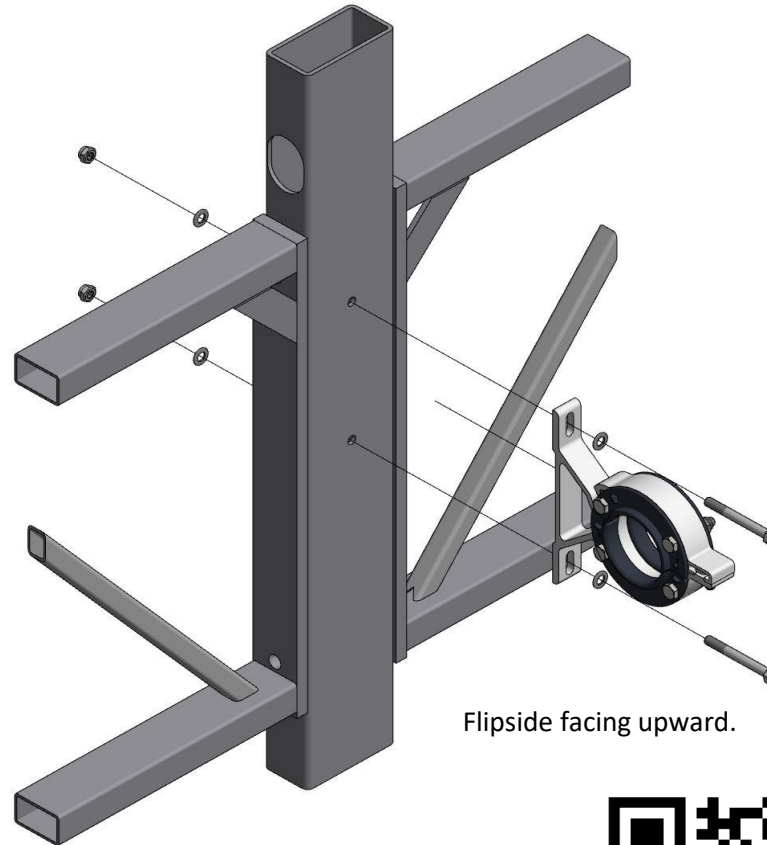

Flipside facing upward.



Package Side



Closing Side

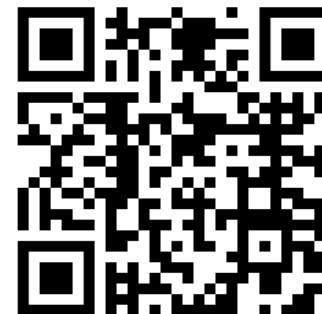
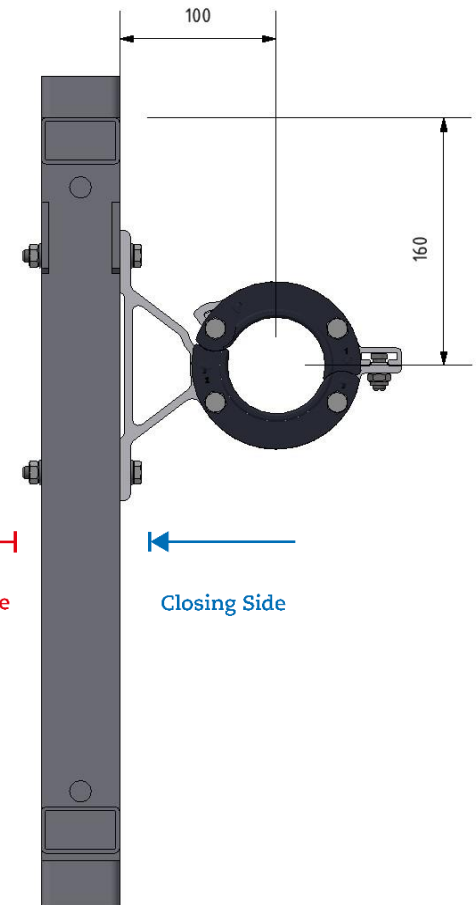

▶ ValkBearingBracket (2") at the floating gutter

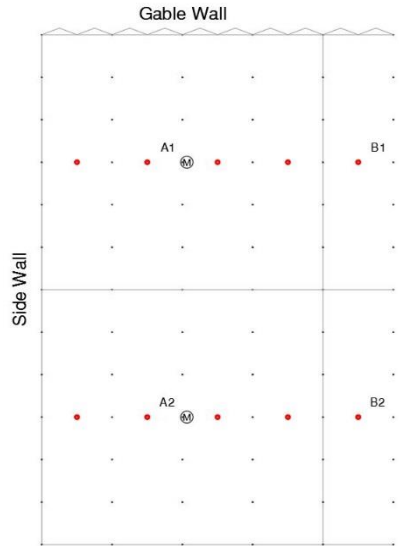

Drill holes $\varnothing 9$ mm in the tube.

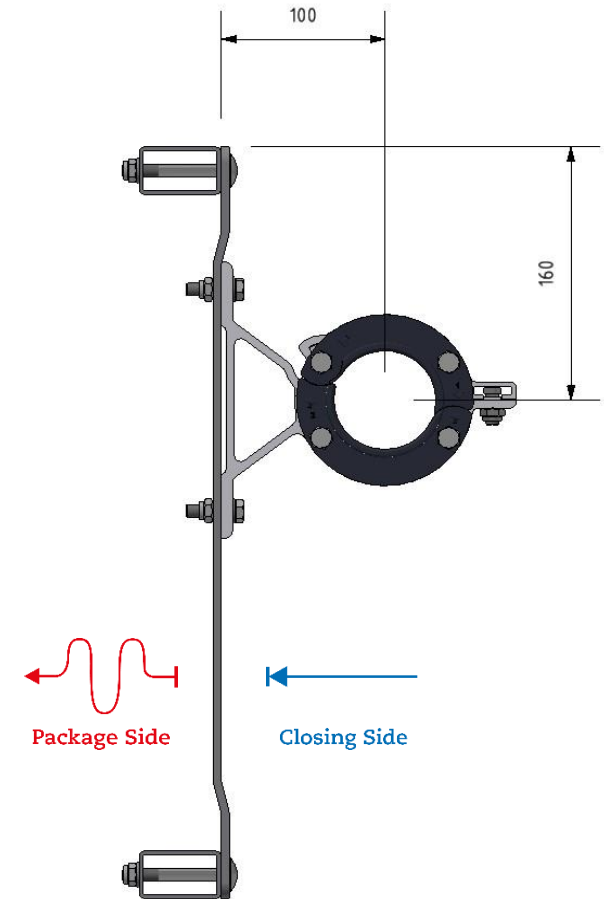
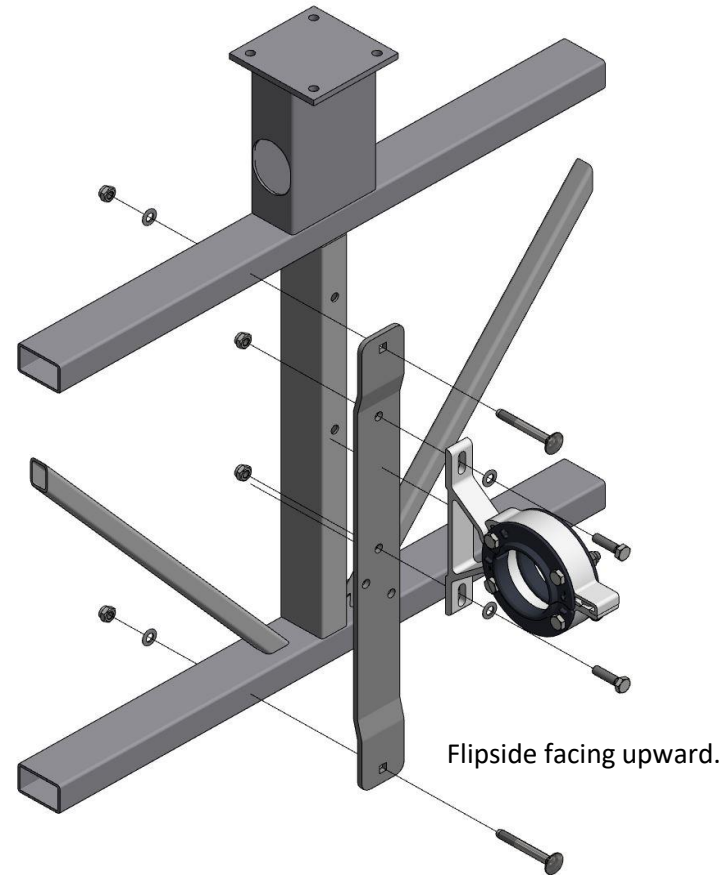

44.82.16



(trellis height)

44.82.10.----



(trellis width +15 mm)

53.41.-- M8x--



55.40.30 M8x30



53.55.17 M8



55.40.05 M8

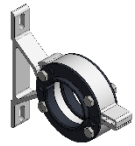
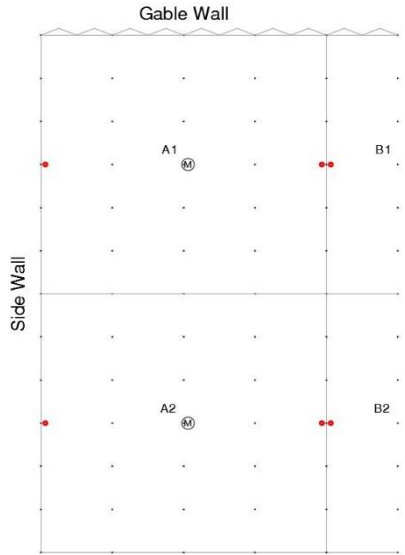

44.82.16



(trellis height)
44.82.10.----



(trellis width +15 mm)
53.41.-- M8x--



55.40.30 M8x30



53.55.17 M8



55.40.05 M8

Section end.

Drill holes $\varnothing 9$ mm in the tube 15 mm below the top of the tube.

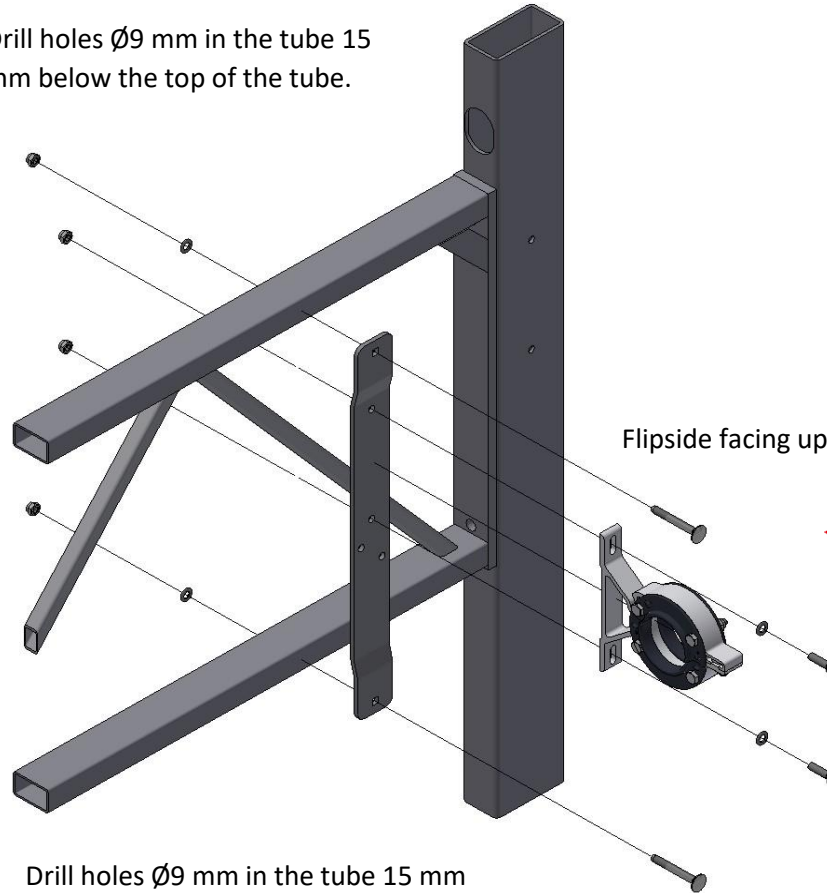

Drill holes $\varnothing 9$ mm in the tube 15 mm above the bottom of the tube.

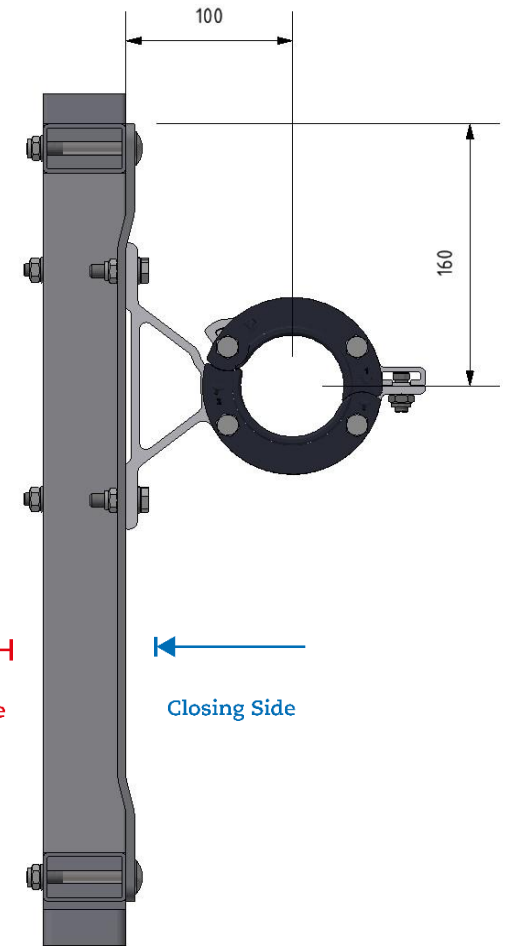

▶ Bracing the ValkBearingBracket at the floating gutter

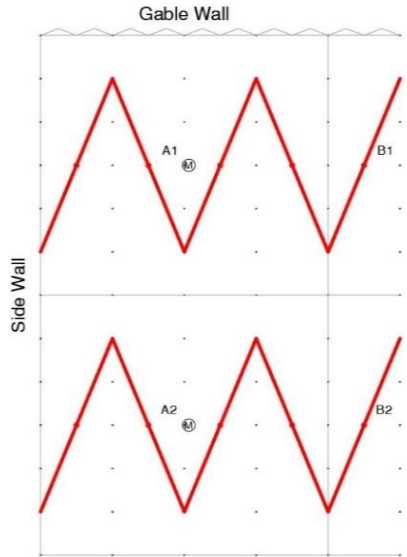

48.10.17



48.80.40



48.80.12



48.80.30



48.80.37

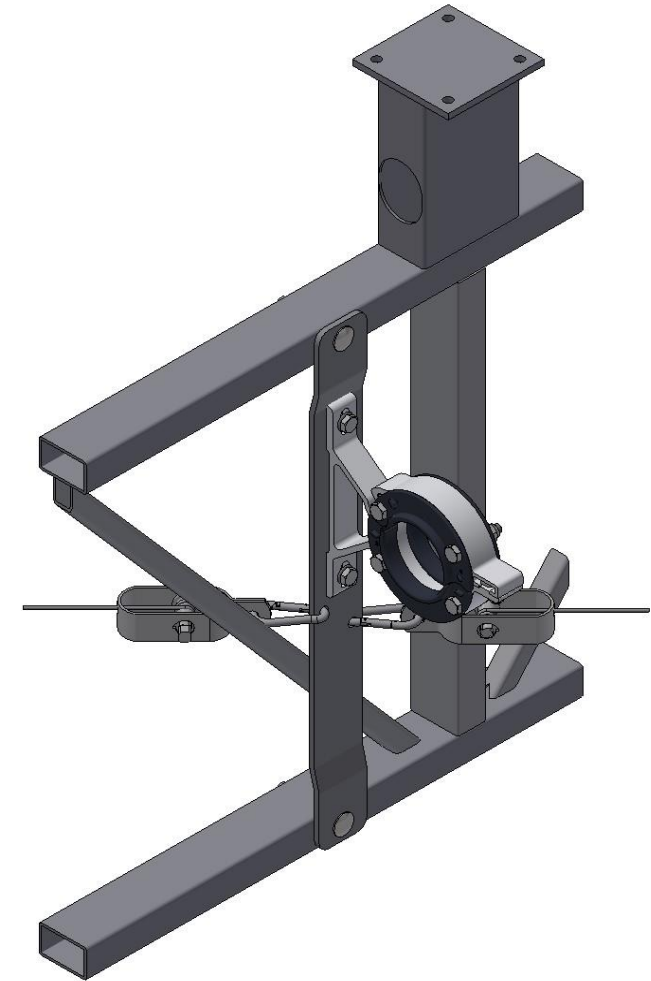
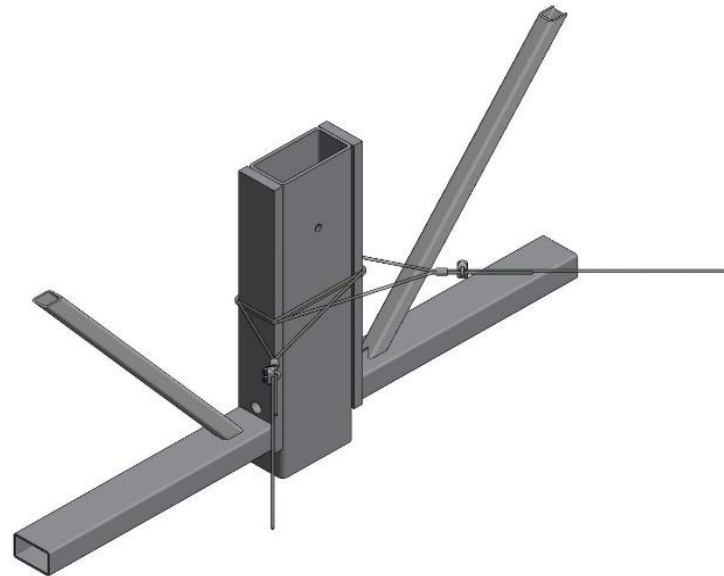

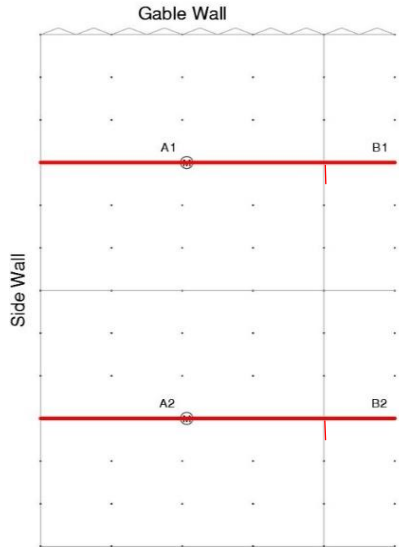

For tightening torque of the wire tensioner see chapter H.





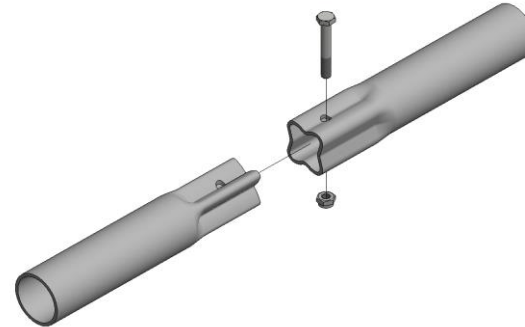



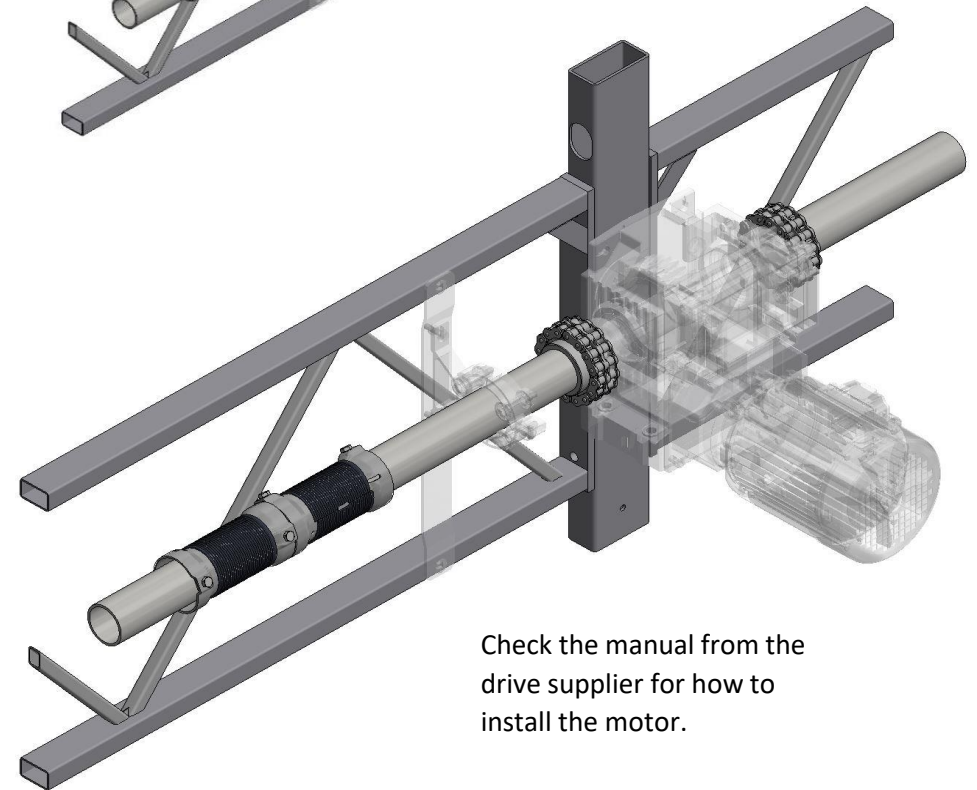

At the section separation use a end cap.

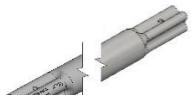

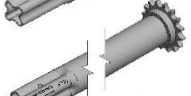
Attention: Slide the wire tensioner on the shaft before installing.



Check the manual from the drive supplier for how to install the motor.

- | | | |
|---|--------------|--------|
|  | 50.42.0---- | |
|  | 52.8--85---- | |
|  | 52.8--86---- | |
|  | 44.80.34-W | |
|  | 53.25.20 | M8 |
|  | 55.40.16 | M8x16 |
|  | 55.50.60 | M10x60 |
|  | 55.50.05 | M10 |
|  | 44.16.60 | |

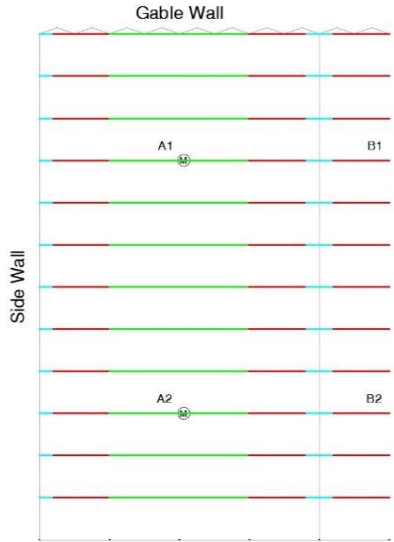

For the correct position of the ValkScreenProfiles, see the project specific drawing.

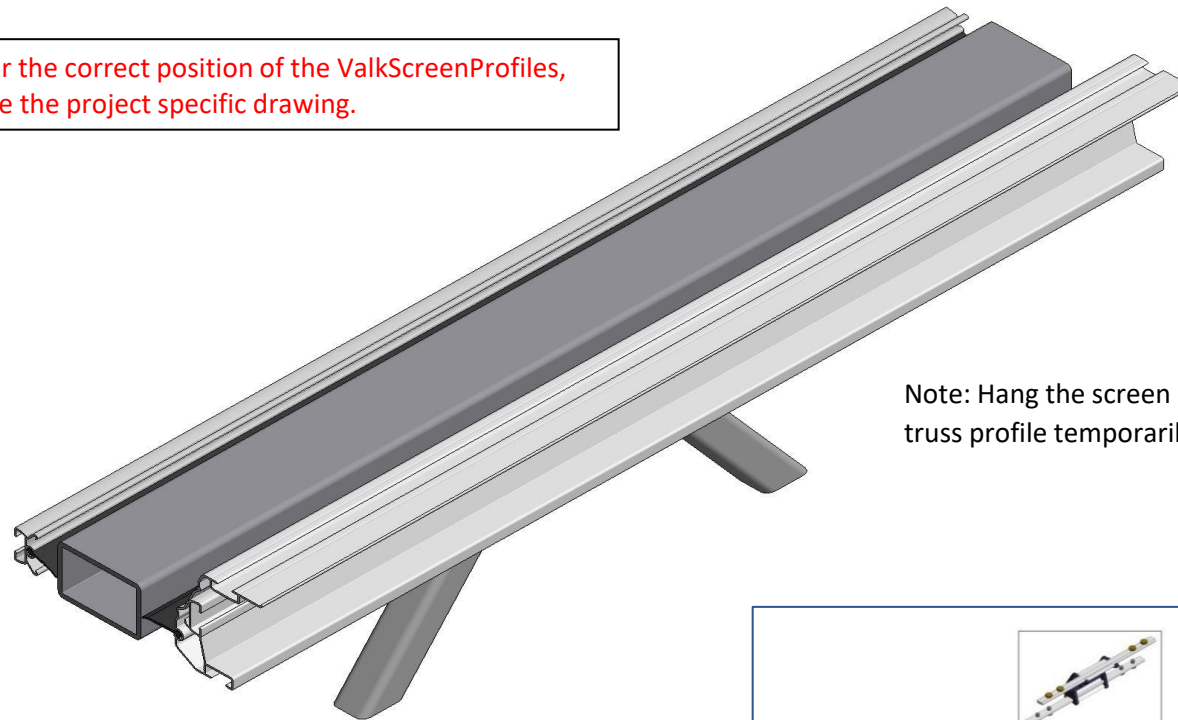

Note: Hang the screen profile and the truss profile temporarily on the trellis.



(profile length)
43.95.20.----



(profile length)
43.93.30.----
VSV 22 mm



(profile length)
43.93.80.----
VSV 35 mm

Don't saw the profiles that are used to pull in the cloth, this to prevent damage and jagged edges on the profile that can damage the cloth. The (1,60m) end sections (in blue color) can be used to cut the profile sequence to the correct length.

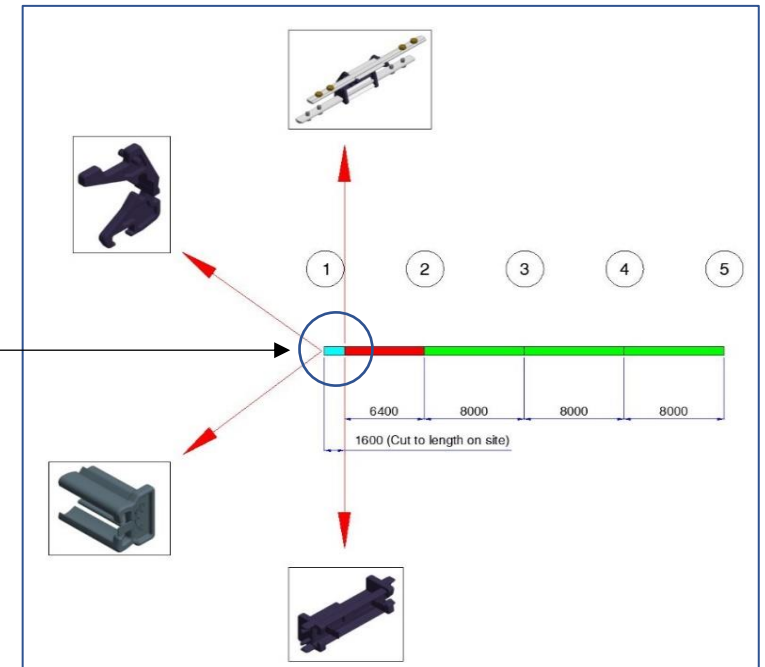

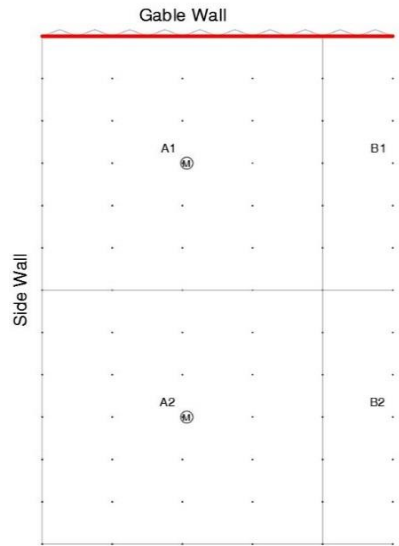

Screen plate at the package side of the screen.

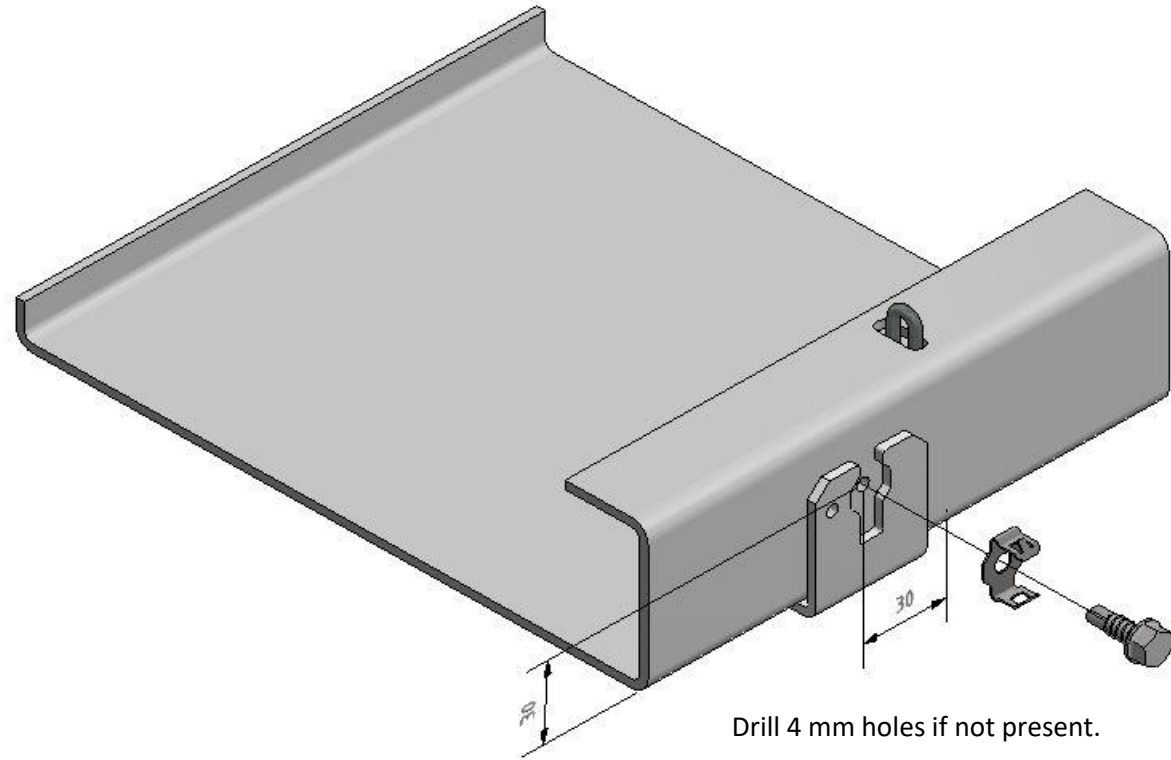

Drill 4 mm holes if not present.

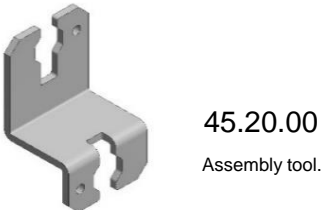
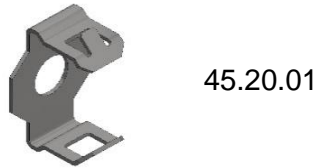

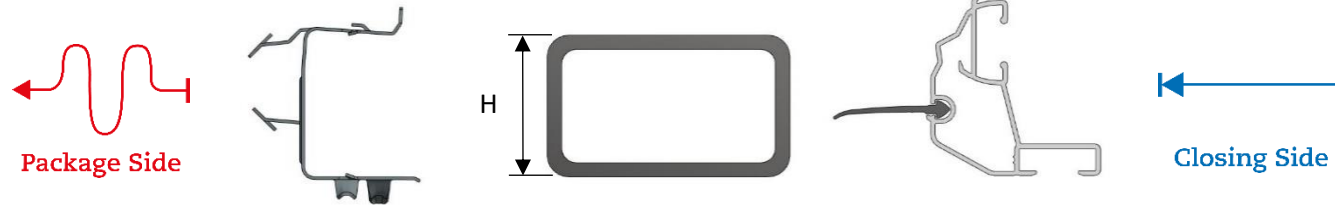
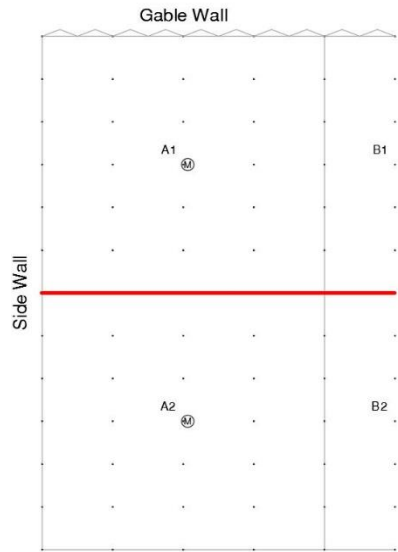

H+3 mm
45.20.--

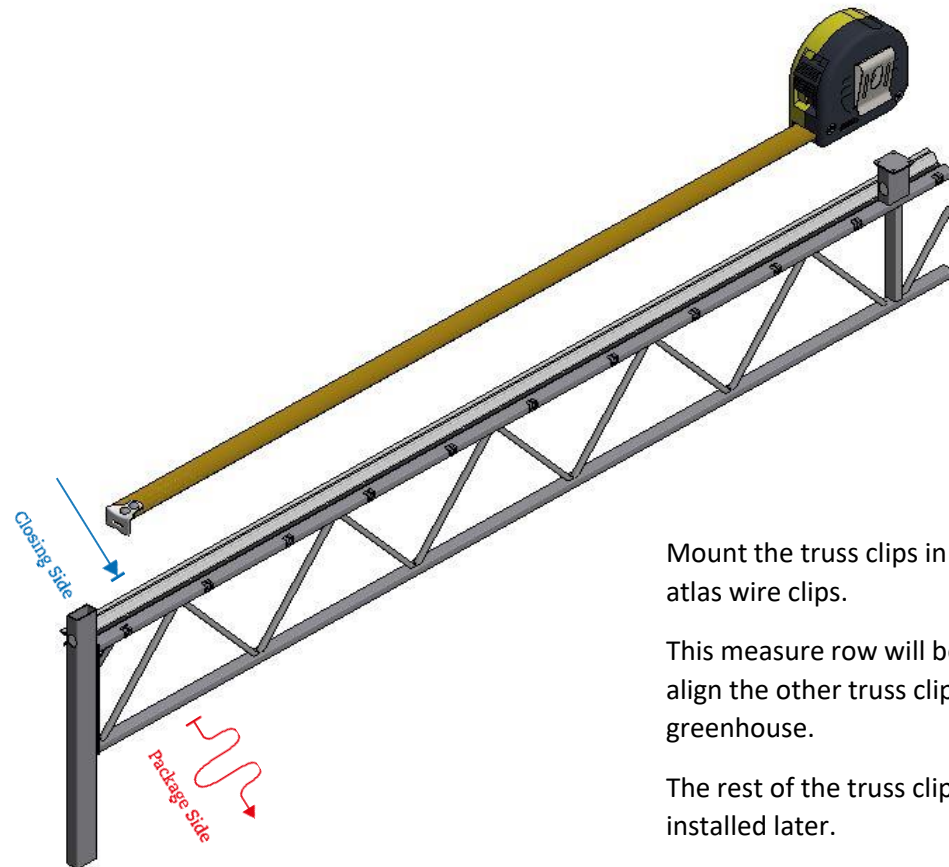

Mount the truss clips in line with the atlas wire clips.

This measure row will be used to align the other truss clips in the greenhouse.

The rest of the truss clips will be installed later.

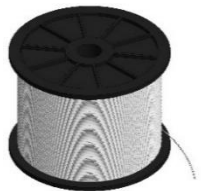
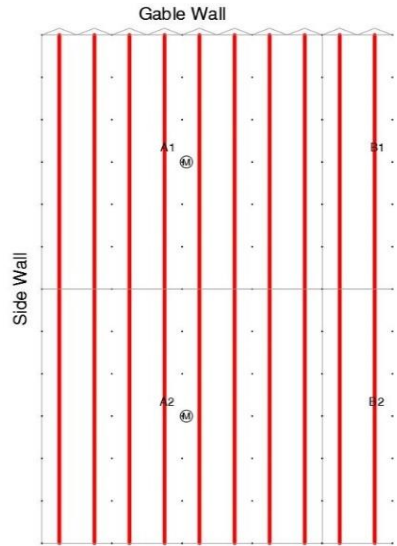

48.50.30

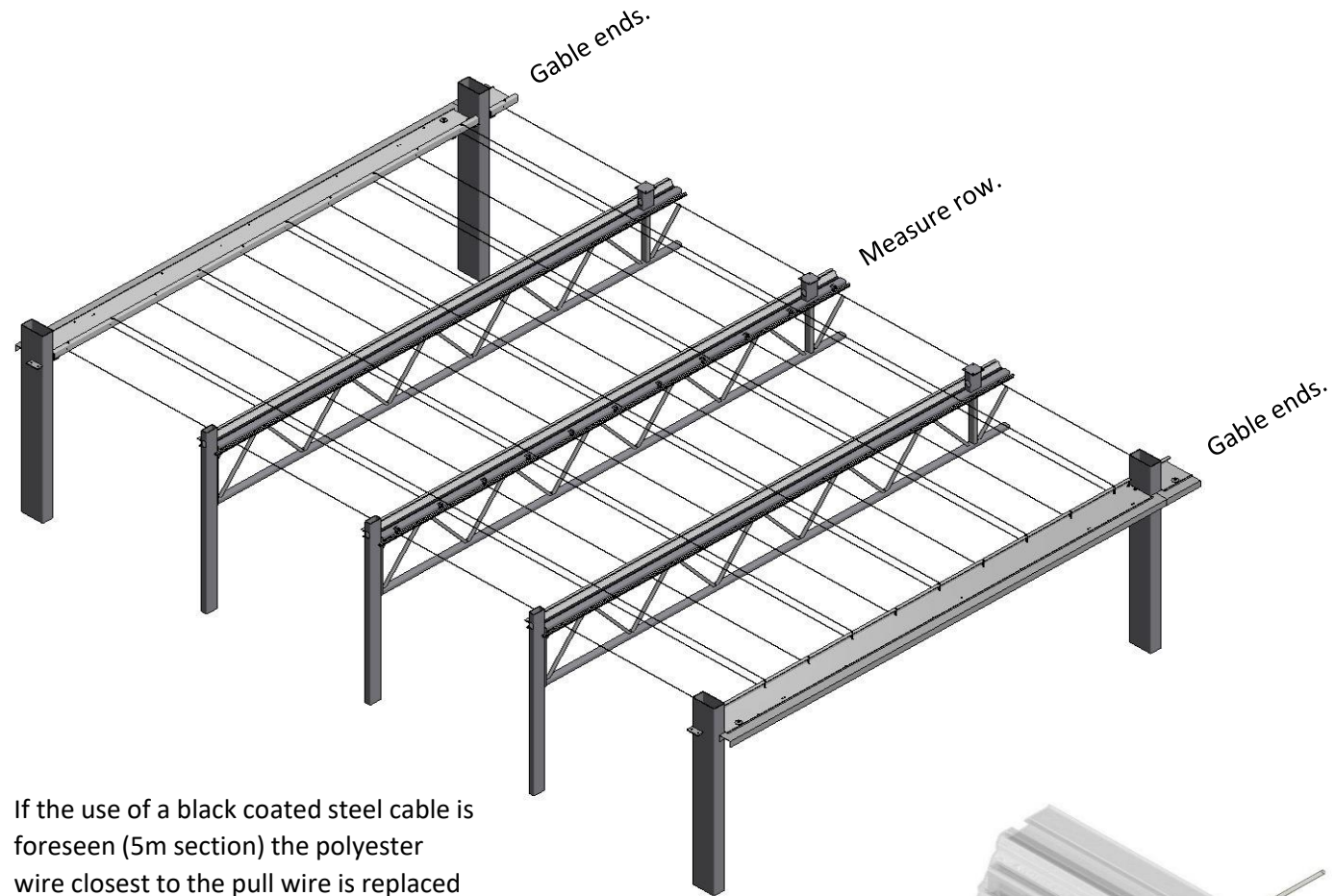

If the use of a black coated steel cable is foreseen (5m section) the polyester wire closest to the pull wire is replaced by this cable. (see next page)

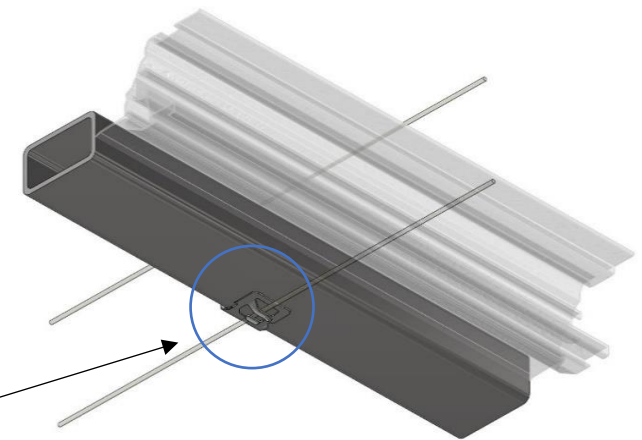

"Click" the polyester wire in the truss clip at the measure row.

▶ Extra black coated steel support cable

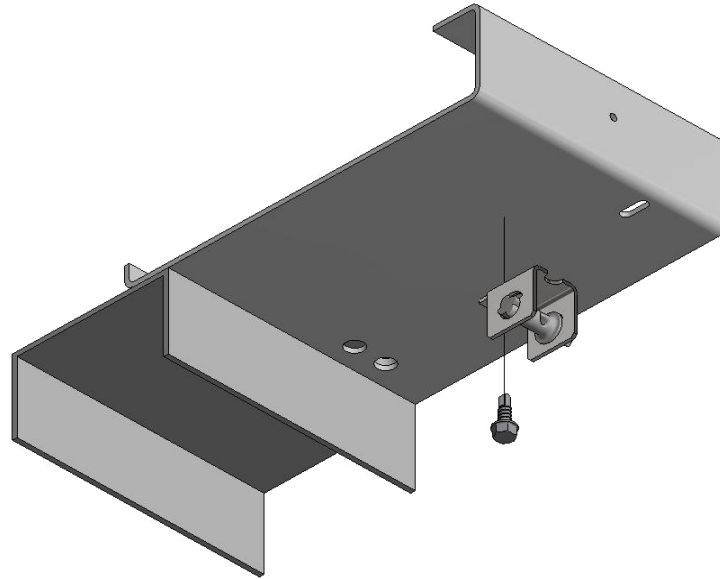
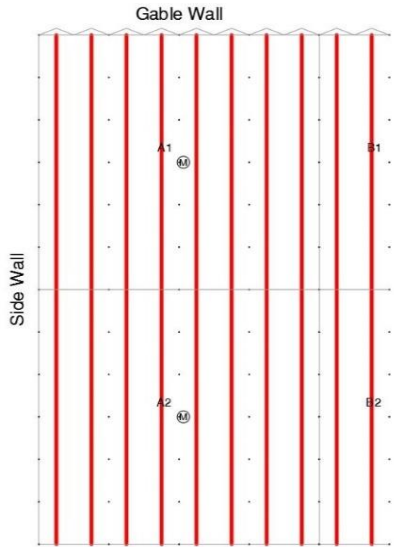

48.20.15



48.80.10



53.57.20

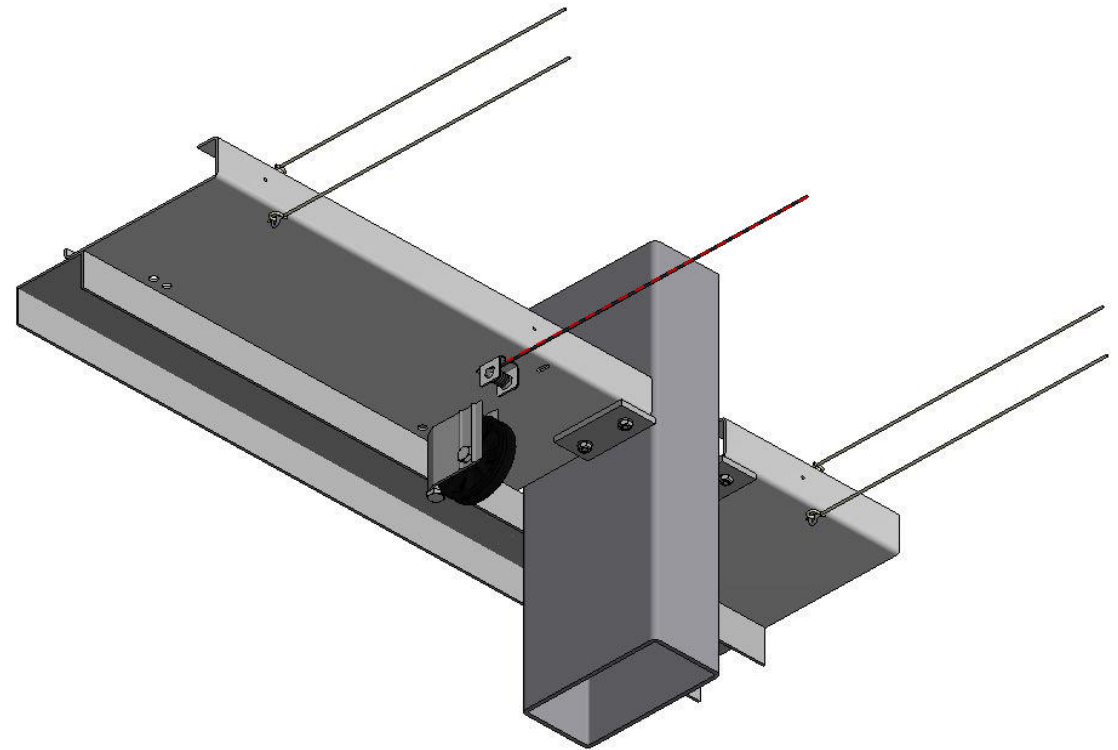

1. Make sure that the plastic cable drum is moved to the side where the knot will be placed, this to make sure there is enough space on the other side for the torque wrench.

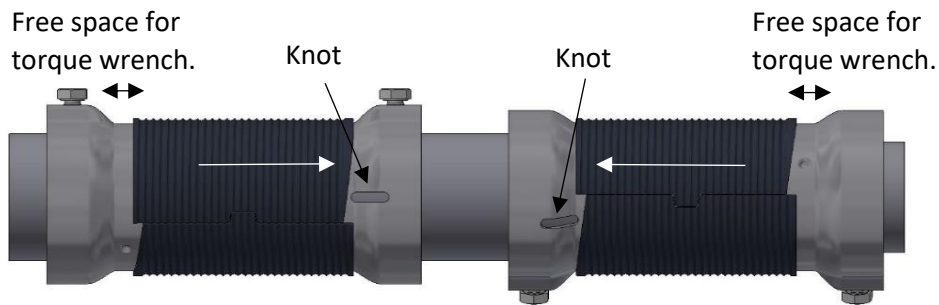

2. The holes in the plastic cable drum stand for how much wire needs to be on the wire tensioners at a certain section size.

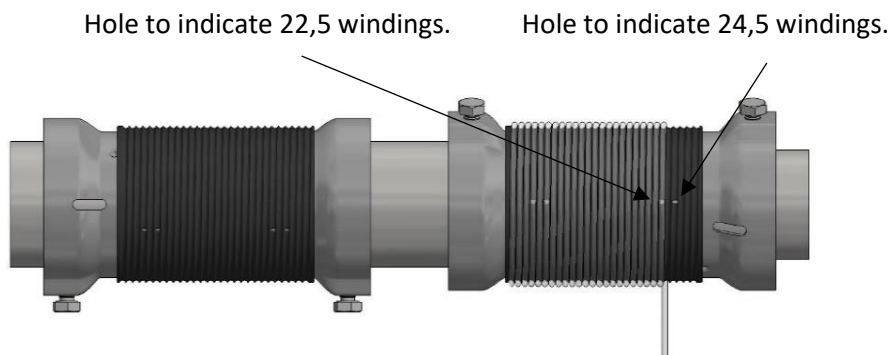

Section size [mm]	No. of windings on wire tensioner 1	No. of windings on wire tensioner 2
3200	3,5	17,5
3658	3,5	19,5
4000	3,5	20,5
4500	3,5	22,5
5000	3,5	24,5

3. Tie a knot at the end of the wire and place the required number of windings on the ValkWireTensioner.

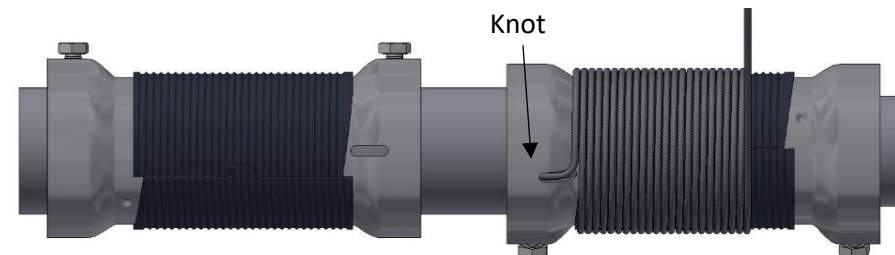

4. Slide the ValkWireTensioners together in such a way that the knots are hidden between the tensioners.

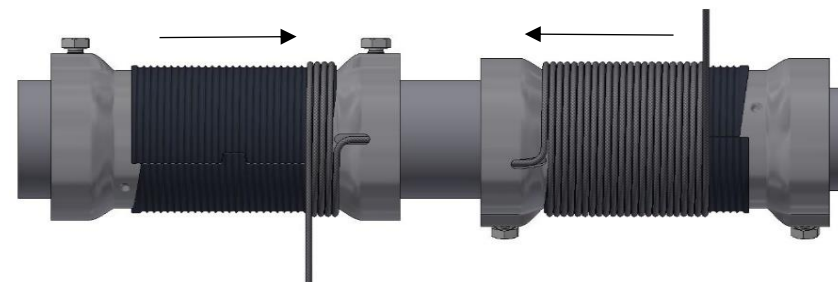

5. Finally, the wire should be wound on the ValkWireTensioner as shown in the picture below.



For the required wire tension, see page H2 and H3



61.16.11



61.16.12



61.16.15

The tools listed above are optional and not standard provided with a screen system. You could order them at Van der Valk Systems.



Place the torque wrench 61.16.11 next to the ValkWireSleeve on the remaining piece of the ValkWireTensioner.

For the required wire tension see page H3.

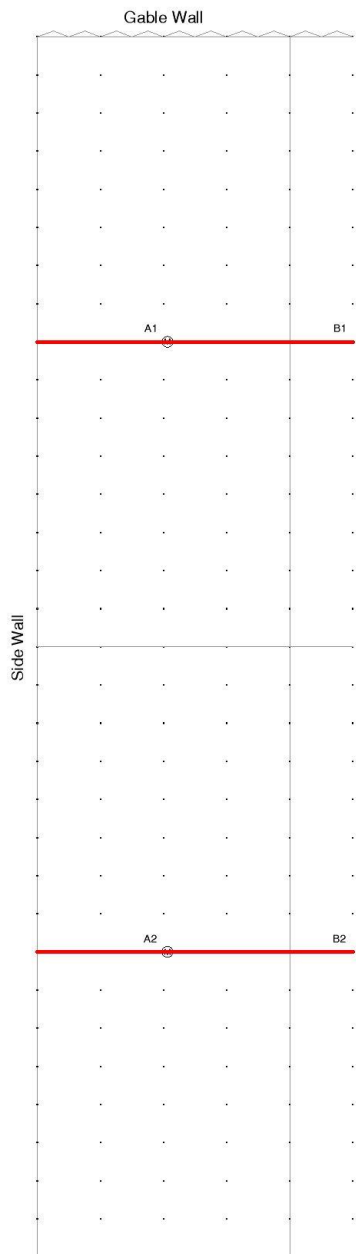

ValkKliMax green has a max. skid force of 3 kg.
 ValkKliMax blank has a max. skid force of 6 kg.
 ValkKliMax red has a max. skid force of 9 kg.

In the neutral position (= mounting position) there should be a certain pre-tension applied.

This pre-tension is of great importance for the correct operation of the system.

The pre-tension depends on the number of ValkKliMax's on one steel cable.

Calculated Cable tension [kg]	Moment to set on torque wrench [Nm]
40	20
50	25
60	30
80	40
100	50
130	60

$$\text{Cable pre-tension} = \frac{(\text{number of ValkKliMax's} \times \text{max. skid force})}{2} + 20 \text{ kg}$$

Example: See greenhouse on the left with 16 sections of a blank ValkKliMax.

$$\text{Cable pre-tension} = \frac{(16 \times 6 \text{ kg})}{2} + 20 \text{ kg} = 68 \text{ kg}$$

The torque wrench must be set approximately to 35 Nm. (see table)

Attention:

When adjusting the motor in the screen system, ensure that 20 cm of pull cable is fed through the ValkKliMax's when closing the system and when forming the screen package.



3 kg



6 kg



9 kg

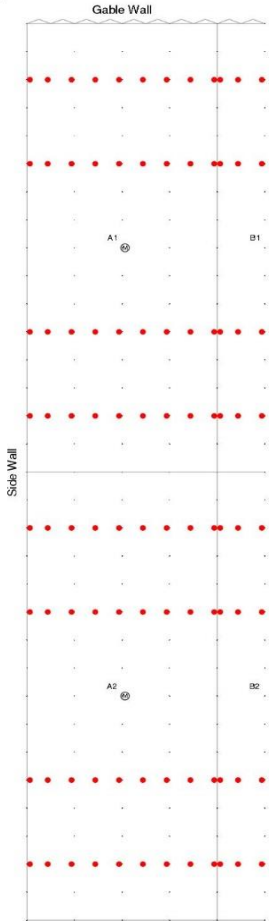

Mount the ValkPulley every 3rd section.



44.27.77

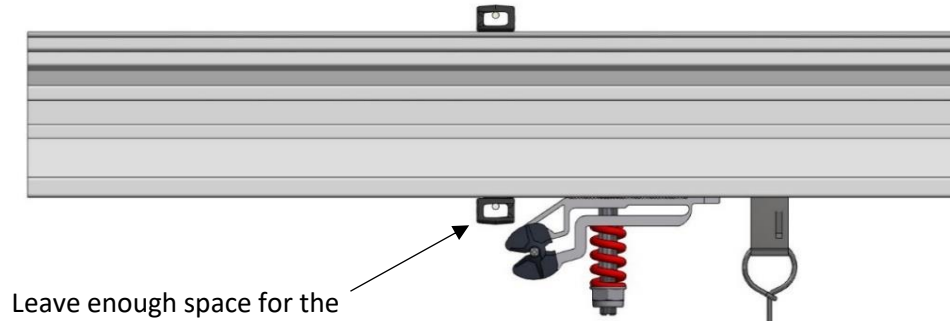

Leave enough space for the ValkWireGuide to slide.

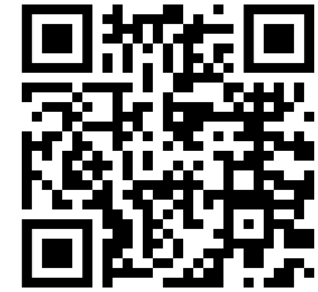
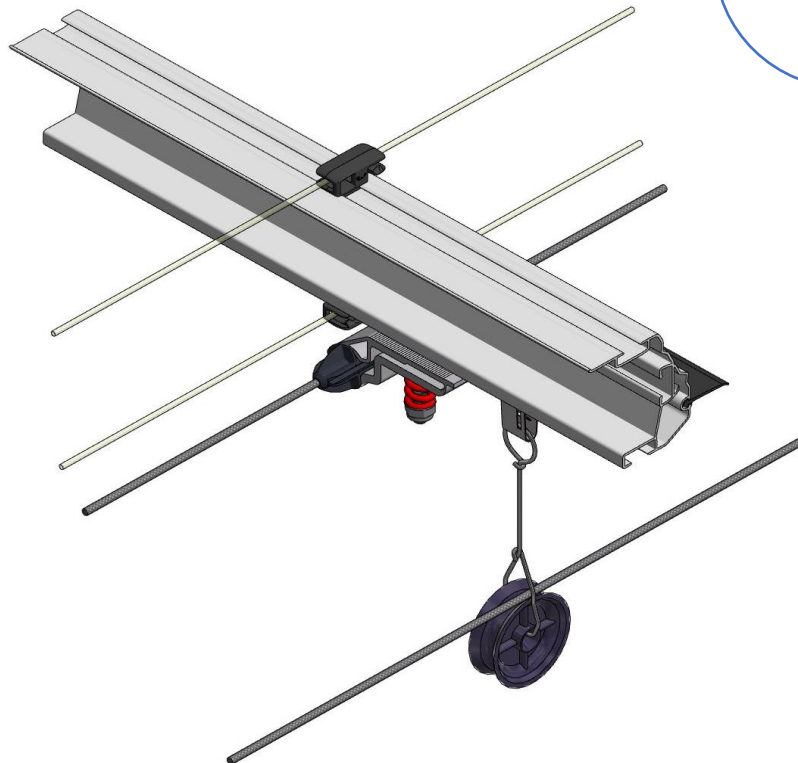

The return wire in the ValkPulley is designed to swing.

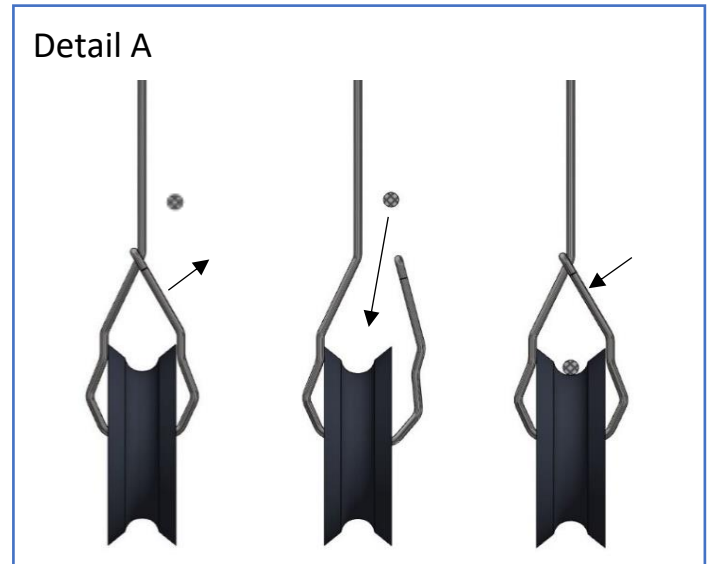

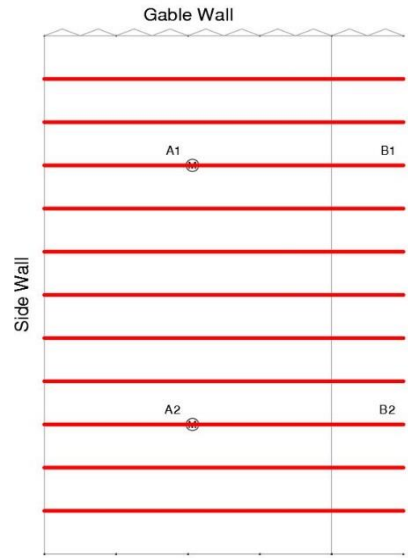

Note: Section J till P could be installed in one sitting.

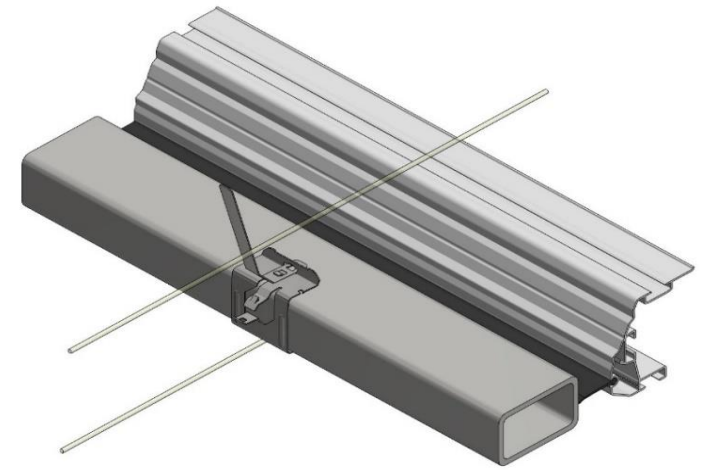
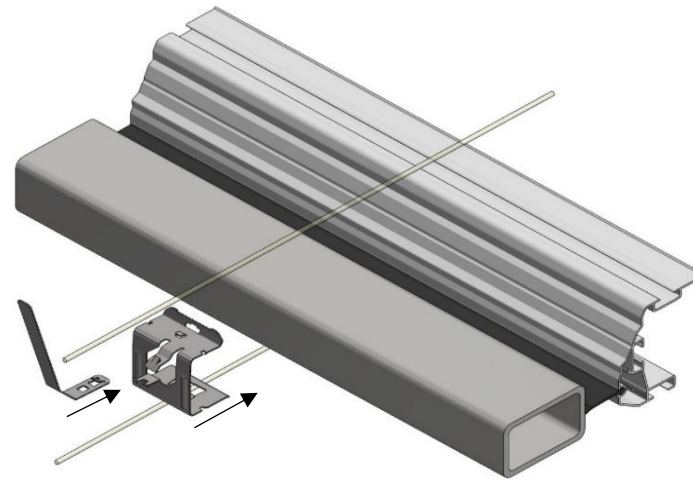

1. Slide the truss clip on the cord of the trellis
2. 'Click' the cloth stop finger on the truss clip.
3. Check if the stop finger is used every truss clip.

Make sure the polyester wire is secured by the 2 lips in the truss clip.



H + 3 mm
45.20.--



45.22.12

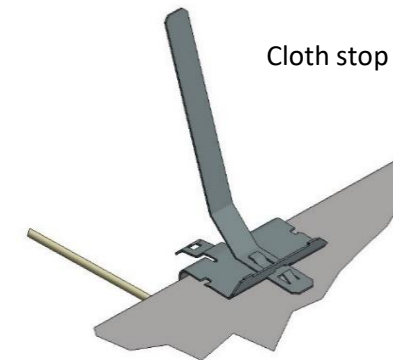
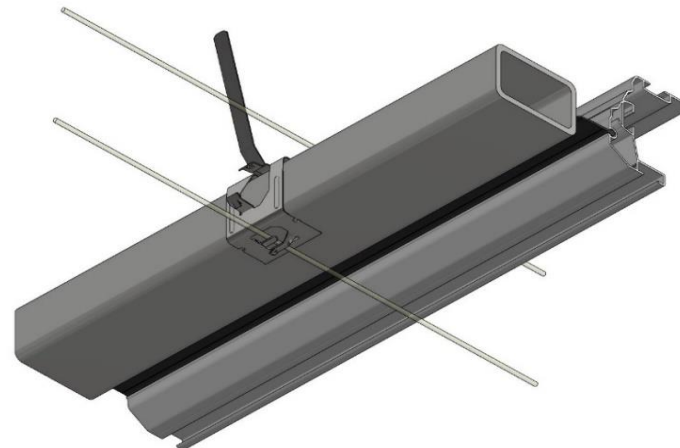

Cloth stop finger.

The rope you pull in, will later be used to pull in the screen cloth. By using the 44.17.00 you can make sure that there are no irregularities in the cloth chamber and that the rope is between the polyester wires.



48.55.03



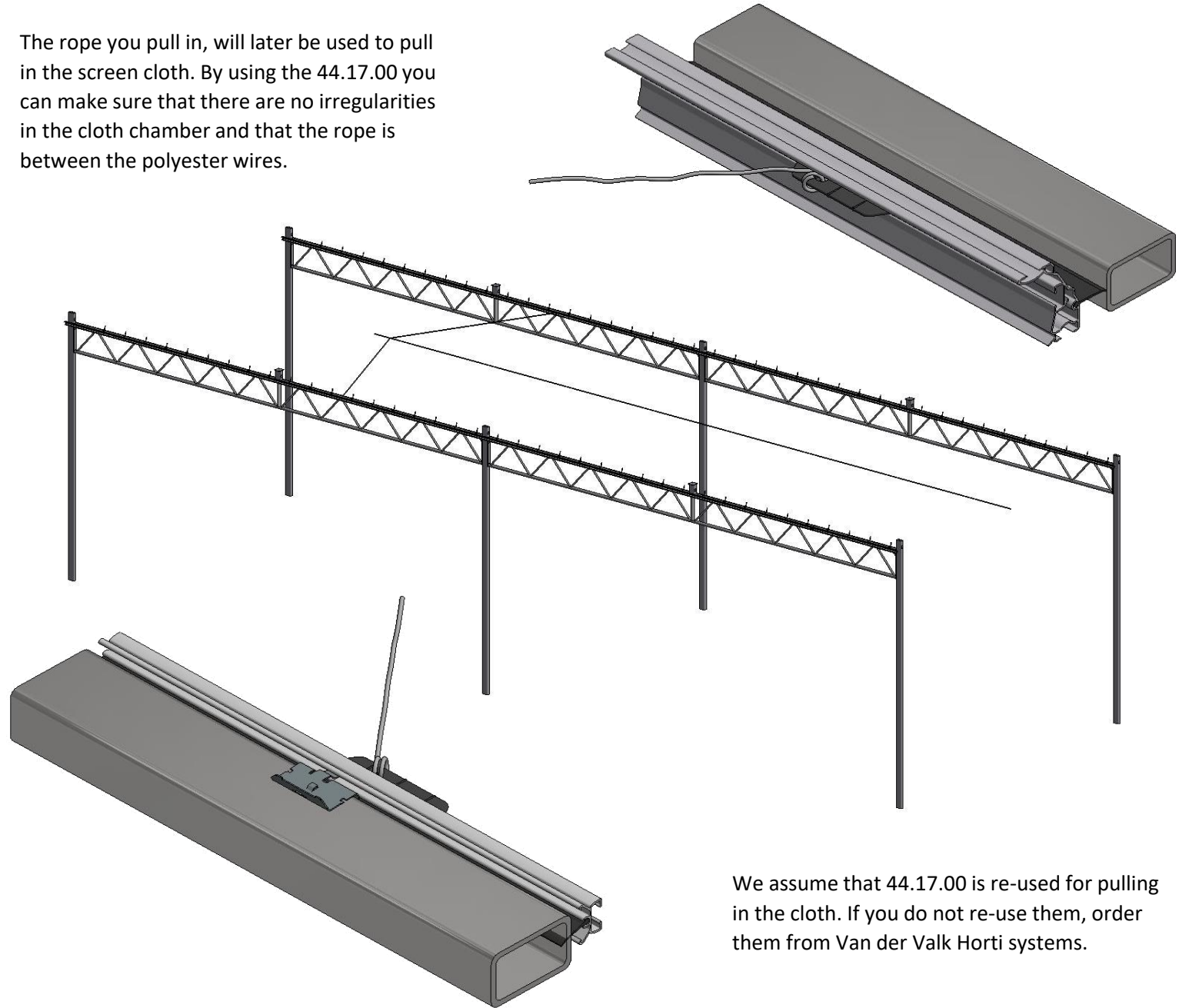

44.17.00

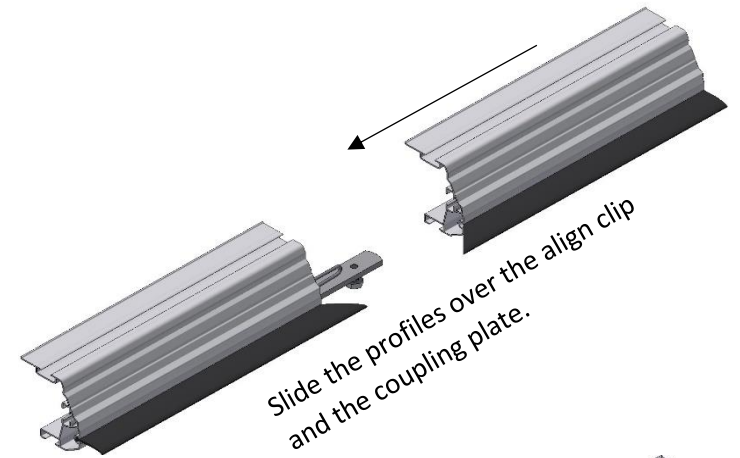
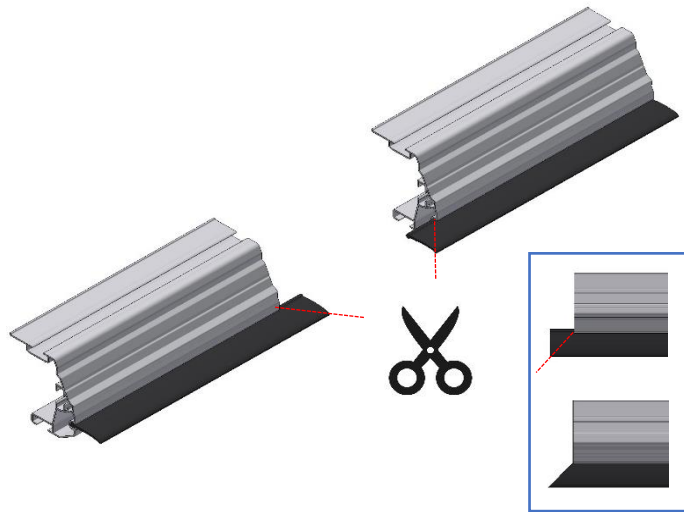
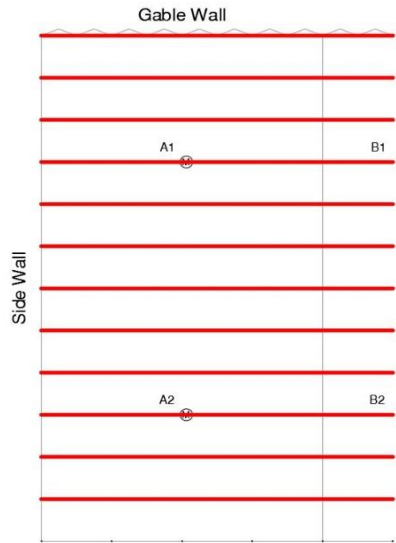

We assume that 44.17.00 is re-used for pulling in the cloth. If you do not re-use them, order them from Van der Valk Horti systems.

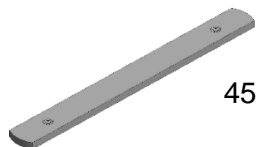

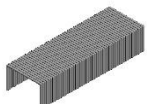
-  45.22.46
-  44.05.10
-  55.30.10 M6x10
-  61.10.06

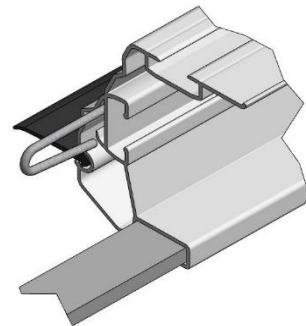

The align clip is mounted for a perfect alignment of the VSV chamber in the VSV profiles.



Attention:
For the profile sequence see page E1 or the project specific drawing.

Attach the 2 rubber ends together with 2 staples.

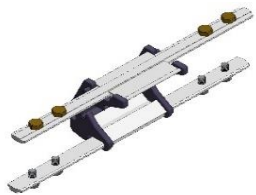
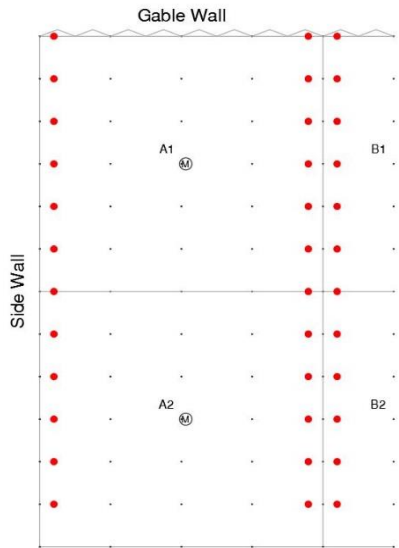

44.17.22
VSV 22 mm

44.17.23
VSV 35 mm

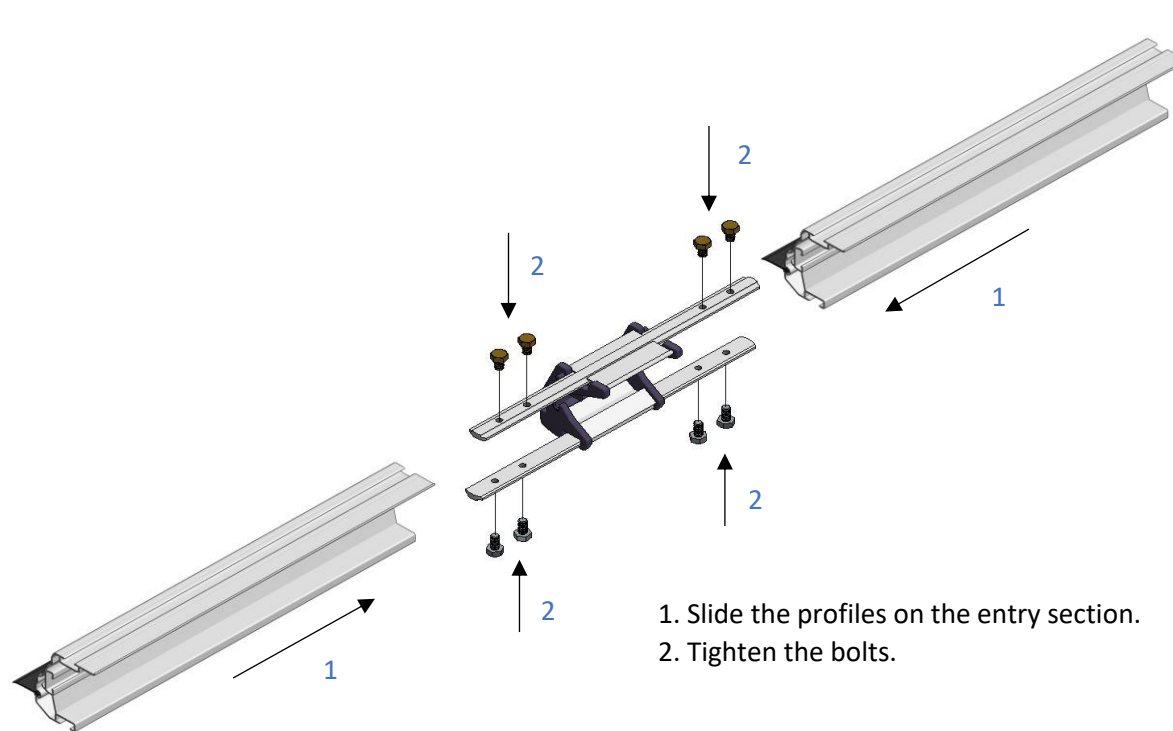

1. Slide the profiles on the entry section.
2. Tighten the bolts.

Position the entry section so that there is a free path for the cloth during pulling in the cloth. Be aware that the cloth also has to slide over the PVC cloth guiding tube, which must be installed in the trellis.

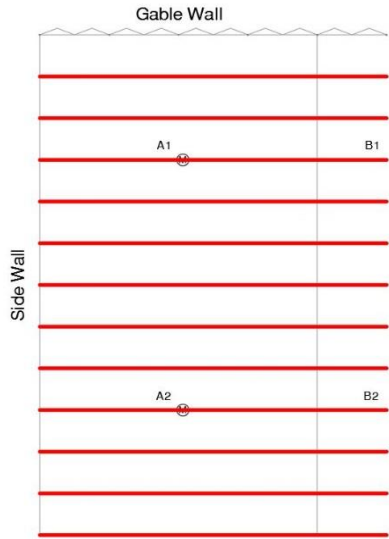

44.15.61

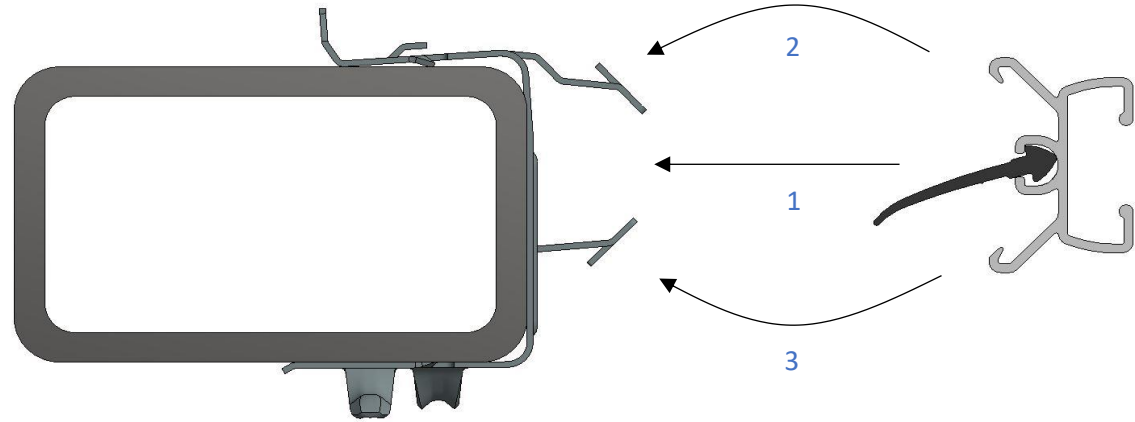
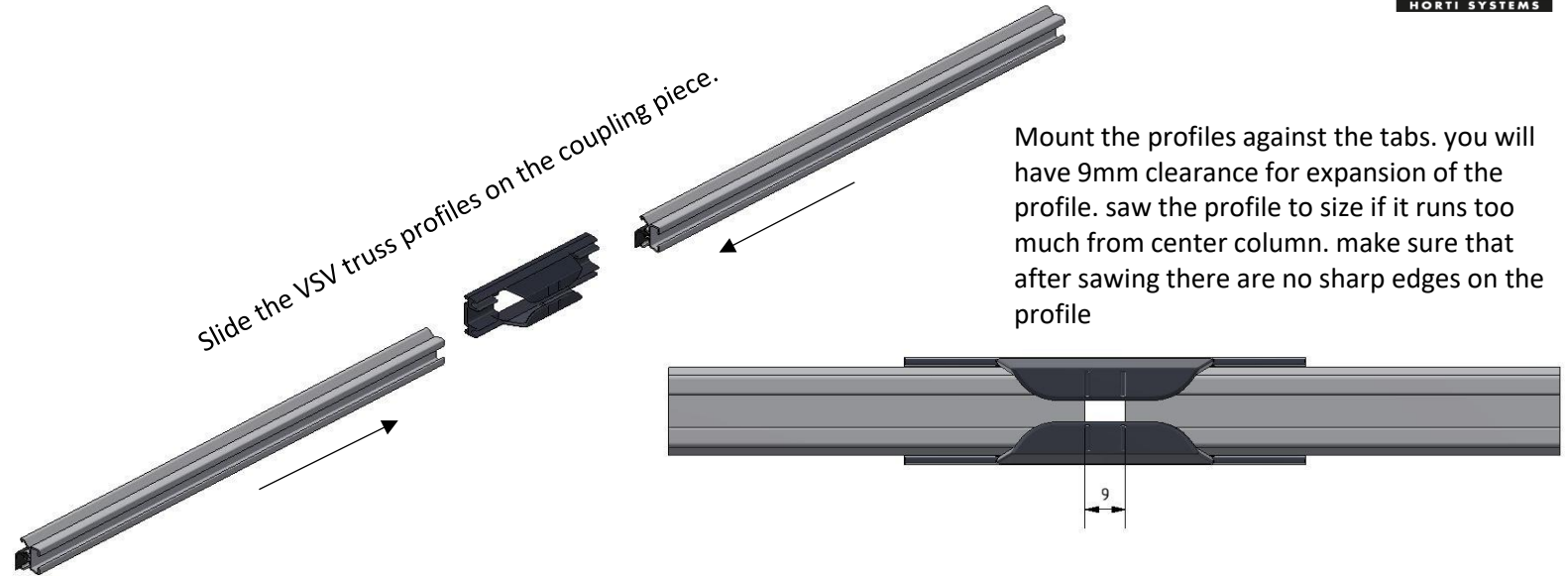

After coupling the VSV truss profile, click the truss profiles on the truss clips.

Note: Couple the truss profile at the column, except when the the column width and trellis with are not equal. than the coupling must be at least 1 truss clip away from the column.

For installing the entry section see page M4.

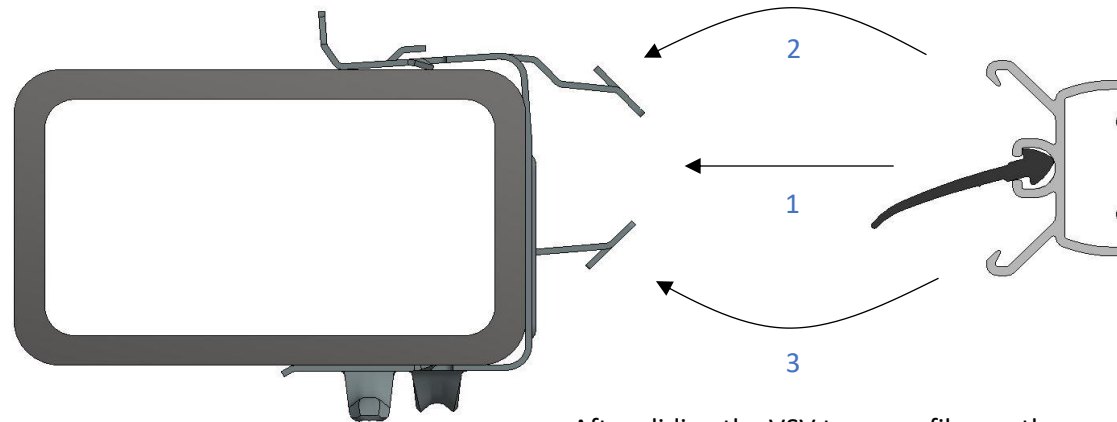
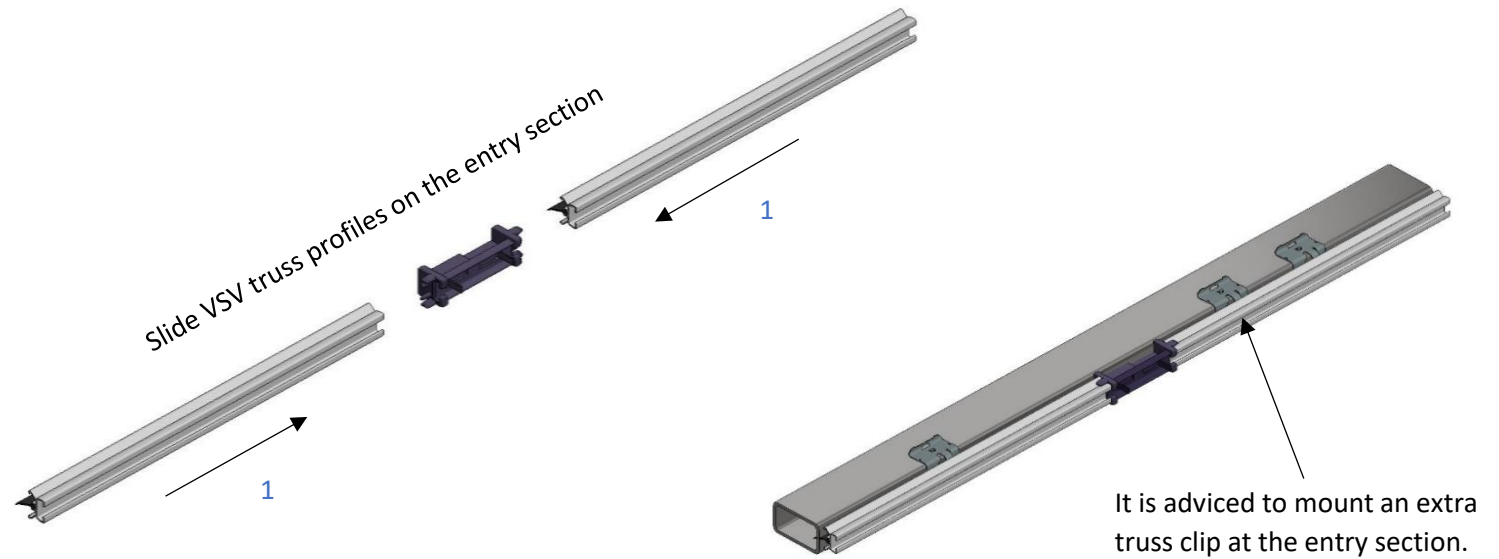
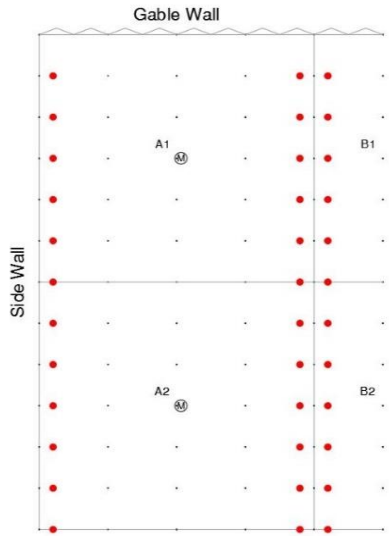

After sliding the VSV truss profiles on the entry section, 'click' the truss profiles on the truss clips.

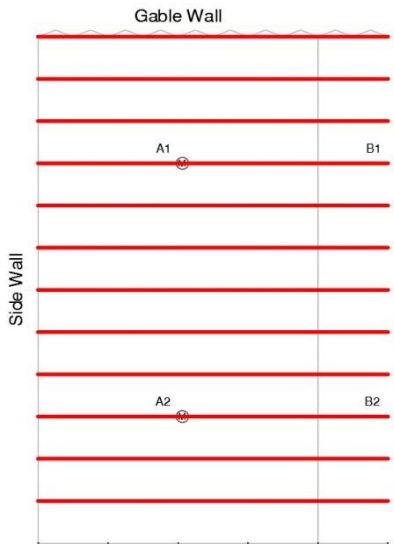

44.15.27

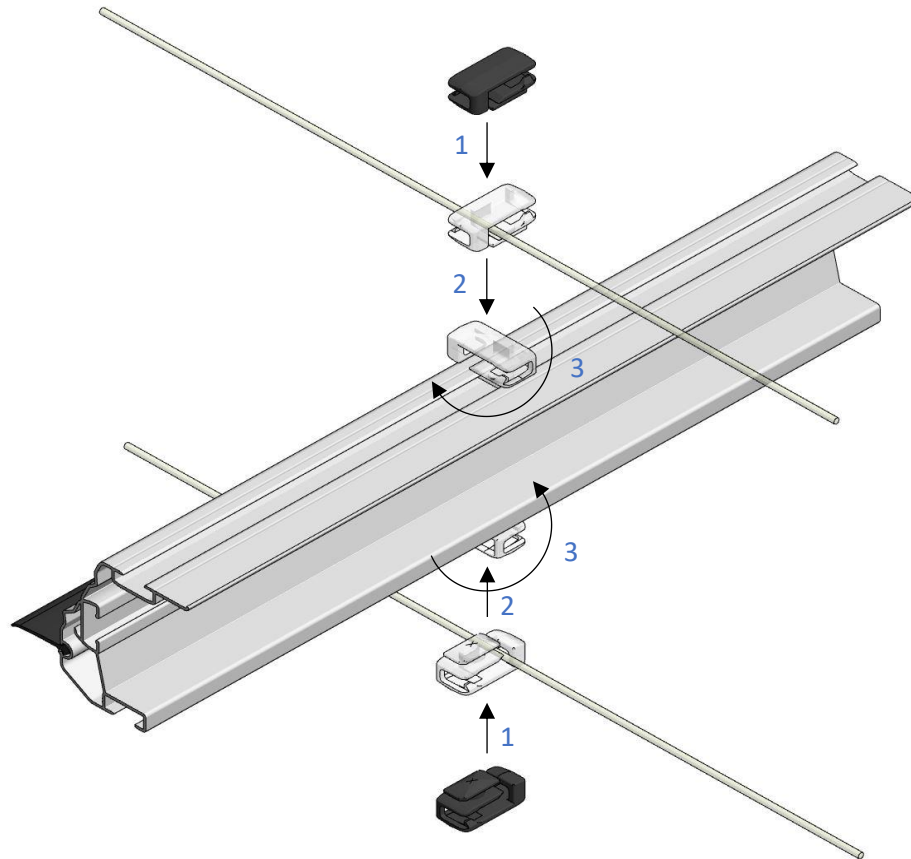

1. Slide the wire guide block on the polyester wire.
2. Insert the wire guide block in the profile chamber.
3. Turn the wire guide block until the wire 'clicks' in the wire guide block, make sure the opening is on the correct side, see the pictures on the right.

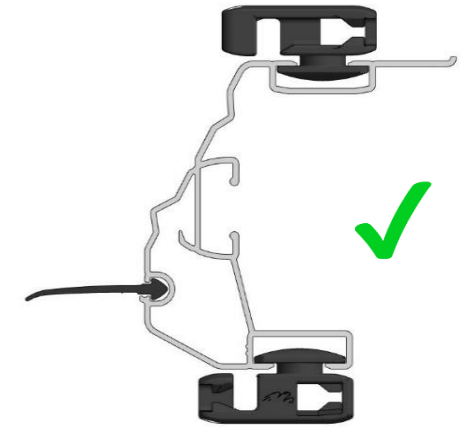

Mount the wire guide blocks with the opening as shown.

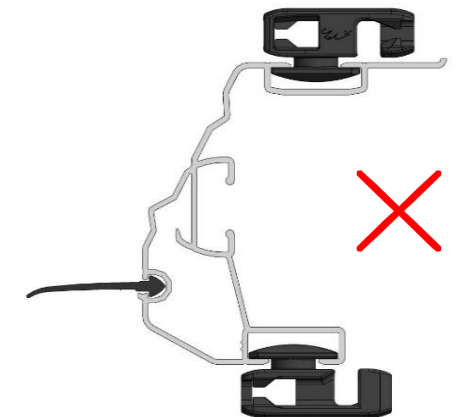

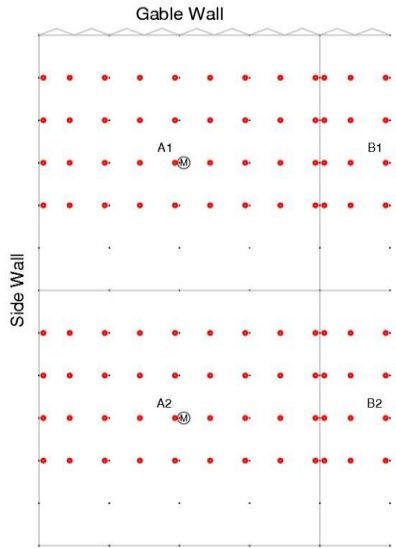

See project specific drawing for mounting the correct ValkKliMax at the correct location!

The ValkKliMax in the sections next to the reversing wheel are slidable. The side wall ValkKliMax's are red spring ValkKliMax's.



- 44.40.34 (green spring 3 kg)
- 44.40.35 (blank spring 6 kg)
- 44.40.36 (red spring 9 kg)

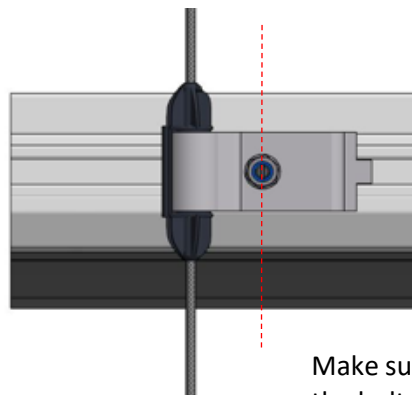

Make sure that the line on the bottom of the bolt is parallel to the cable.

1. 'Click' the pull wire in the ValkKliMax.
2. Mount the ValkKliMax in the profile chamber.
3. Tighten the bolt with a maximum torque of 6 N/m, do NOT use an impact wrench.

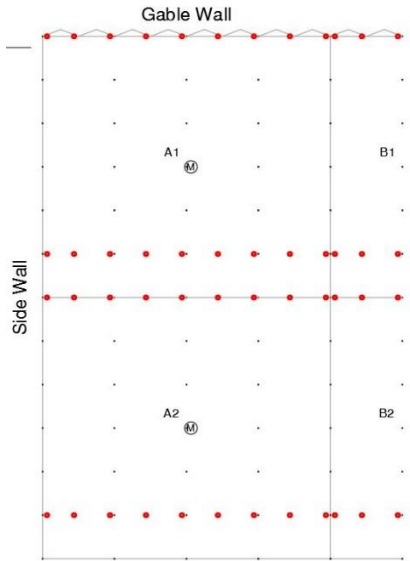

See project specific drawing for mounting the correct ValkKliMax Slide at the correct location!



- 44.40.44 (green spring, 3 kg)
- 44.40.45 (blue spring, 6 kg)
- 44.40.46 (black spring, 9 kg)

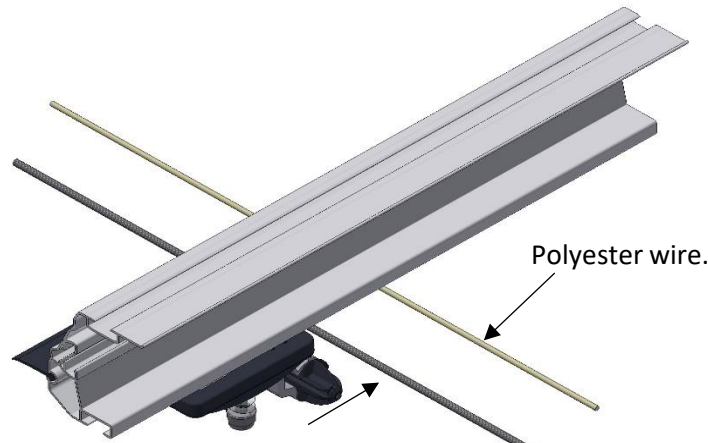
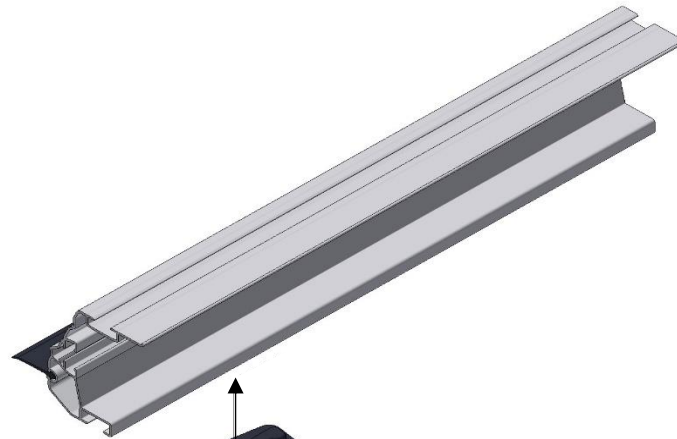

Slide the ValkKliMax Slide on the pull wire with the head towards the polyester wire.

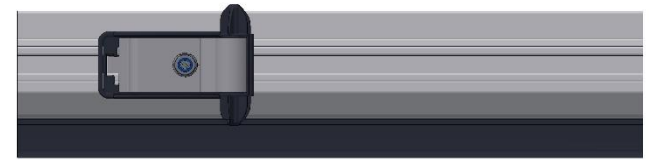
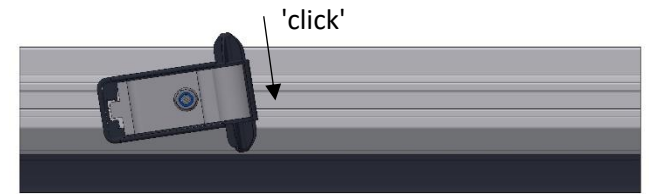

Attention:
Maximum tightening torque 6 Nm, do NOT use an impact wrench.

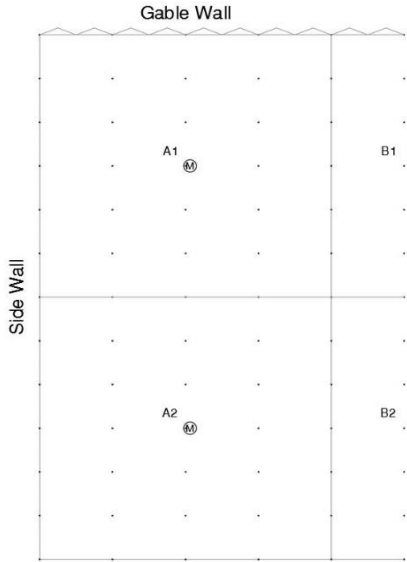

Before the cloth installation, first read and follow the manual and regulations of the cloth supplier.

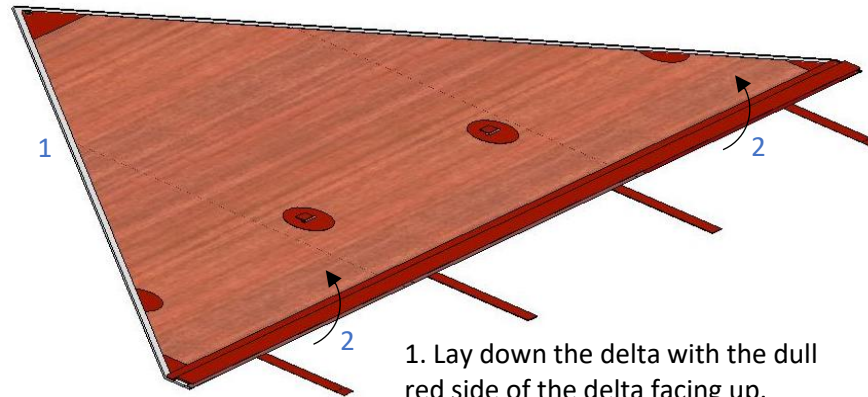

1. Lay down the delta with the dull red side of the delta facing up.
2. Open the flap.

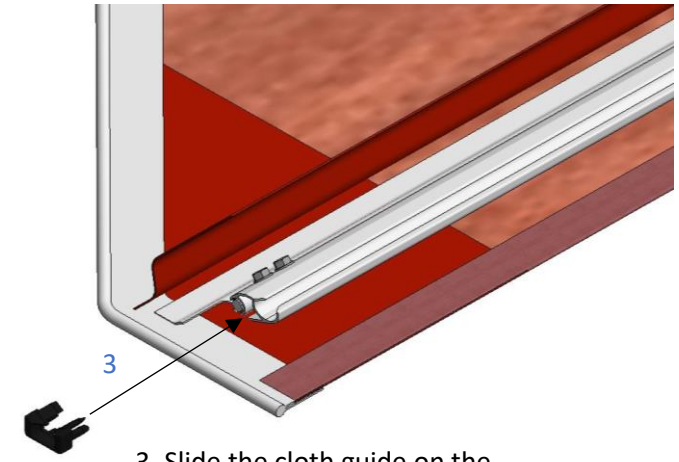

3. Slide the cloth guide on the delta profile (below the flap).



59.84.0 ---



44.17.10



45.20.05

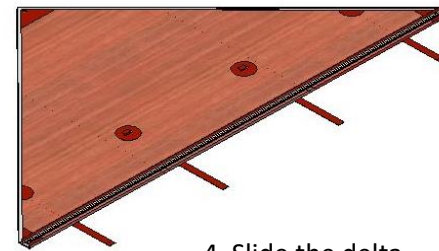

4. Slide the delta on the head strip of the cloth roll.

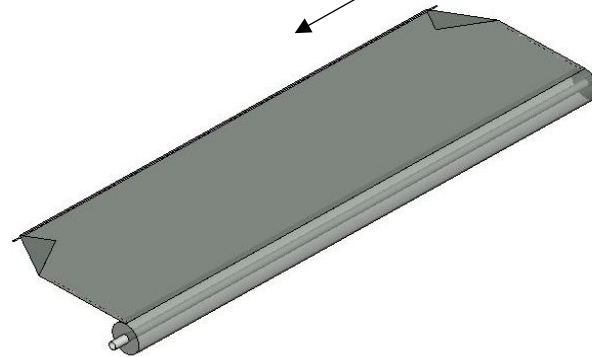

5. Secure the cloth in the middle of the delta with the clip.

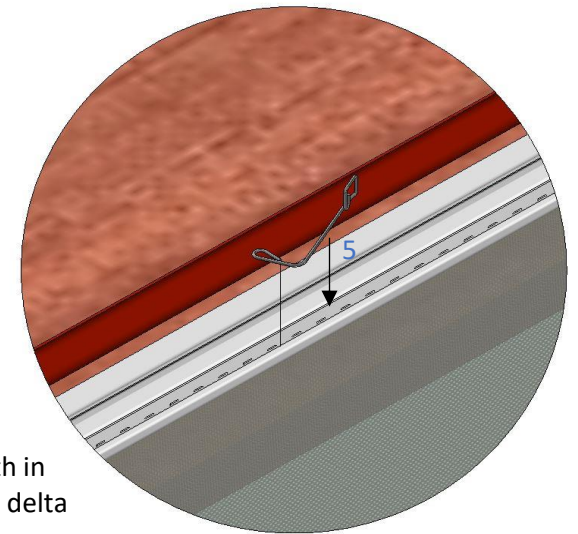

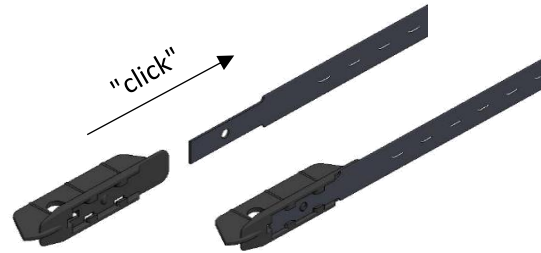
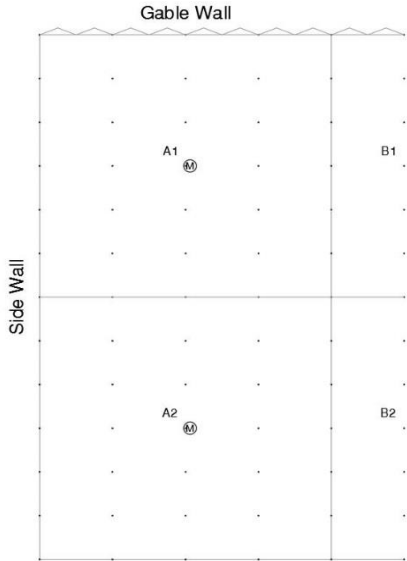

"Click" the front runners at the front end of the strips for a smooth conduction trough the profiles. Mount with the protruding part of the front runners facing each other so that the front runners fits trough the profile chambers. Before clicking the front runners on the strips check the top and bottom side of the cloth.

Mount the winch beam with the straps to the trellis in such a way that when the cloth comes out the insert, it can run in a clear way to the winch.

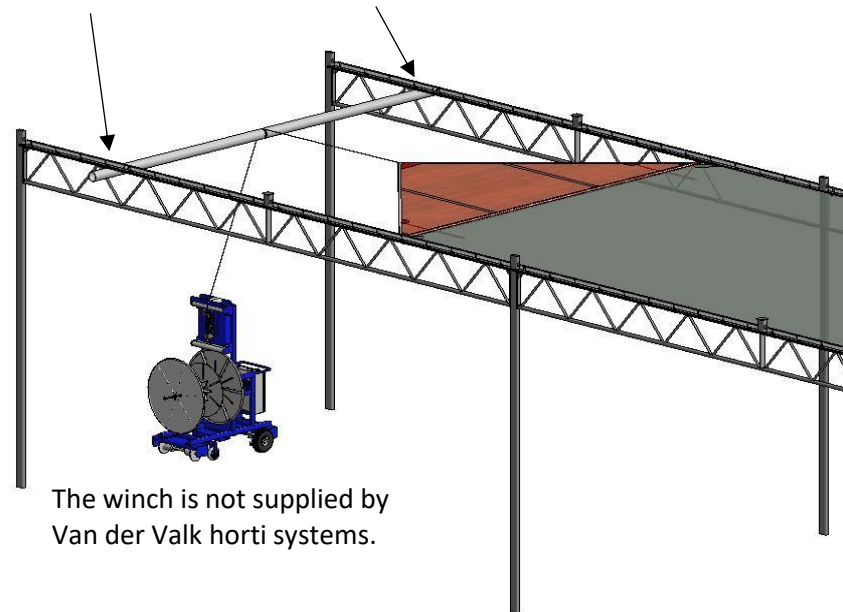

The winch is not supplied by Van der Valk horti systems.

Mount the cloth guiding tube with the straps to the trellis in such a way the cloth that comes from the cloth roll can run in a clear way to the insert.

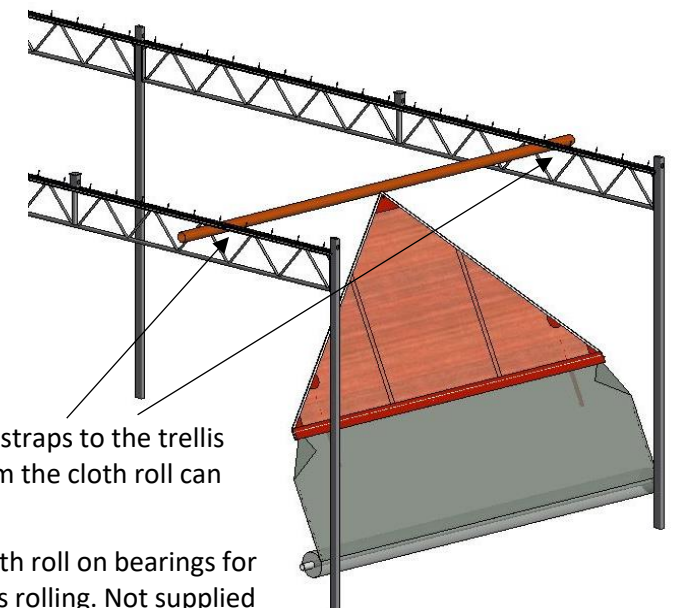

Lay the cloth roll on bearings for friction less rolling. Not supplied by Van der Valk horti systems.



44.17.00



59.77.91



59.78.90



59.77.95

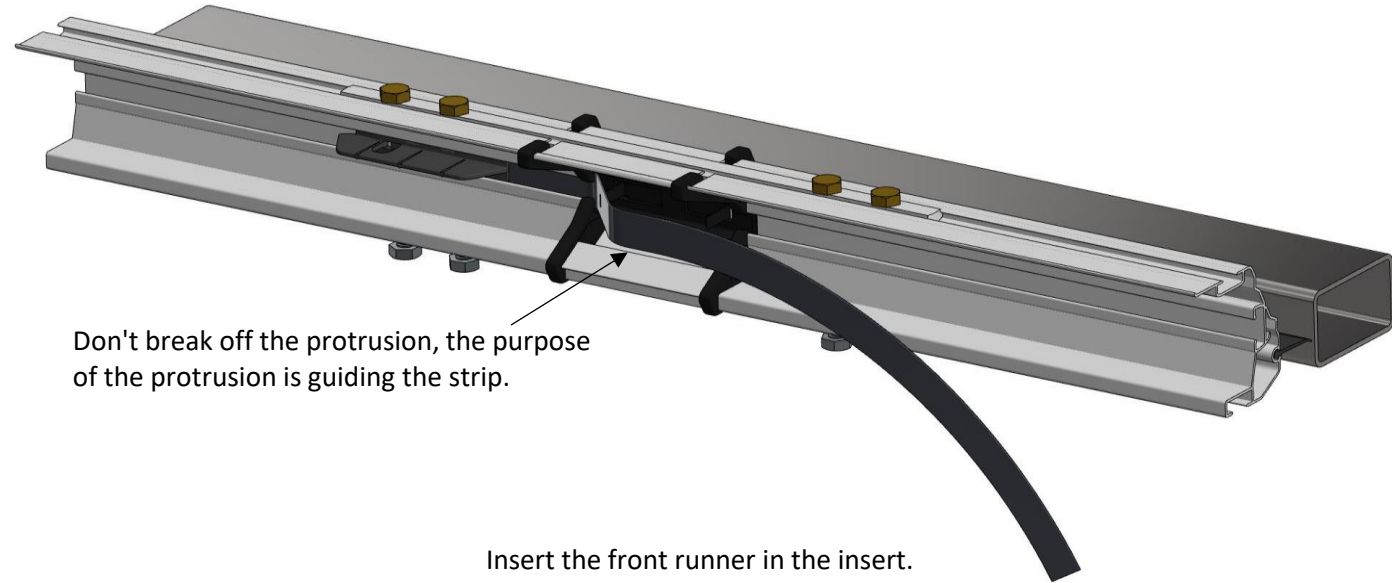
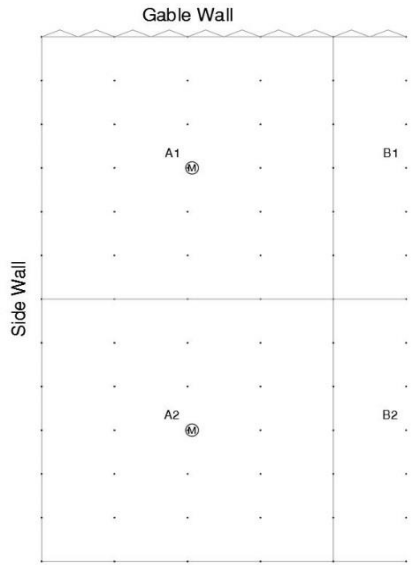

Don't break off the protrusion, the purpose of the protrusion is guiding the strip.

Insert the front runner in the insert. The insert at the end of the profiles forces out the strip again.

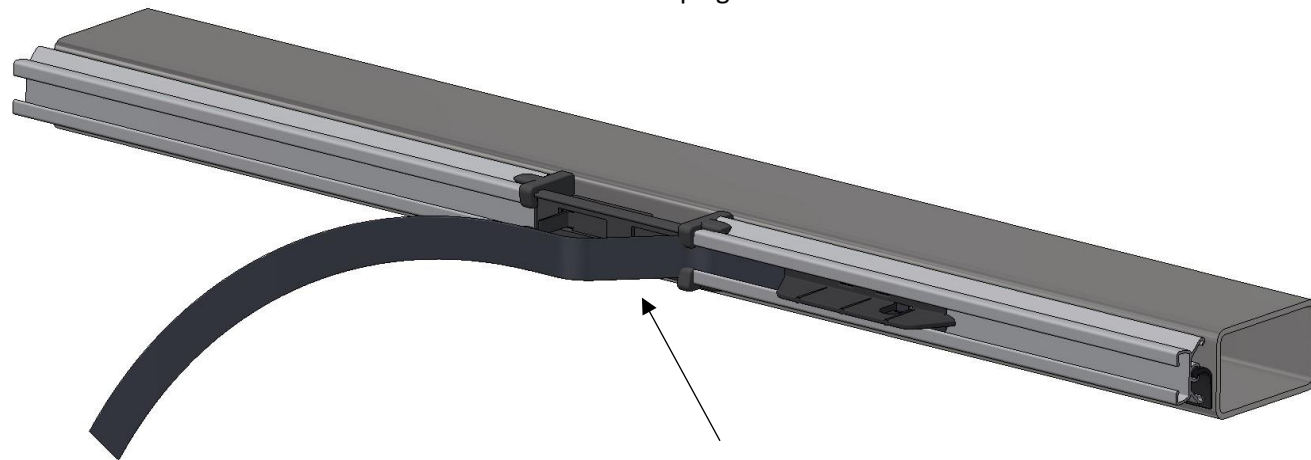

Don't break off the protrusion, the purpose of the protrusion is guiding the strip.

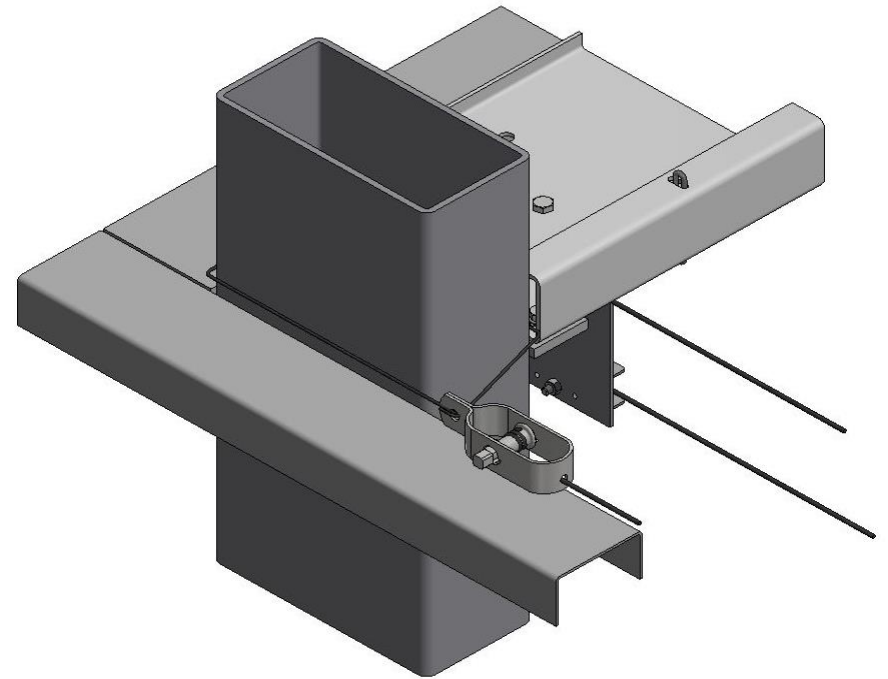
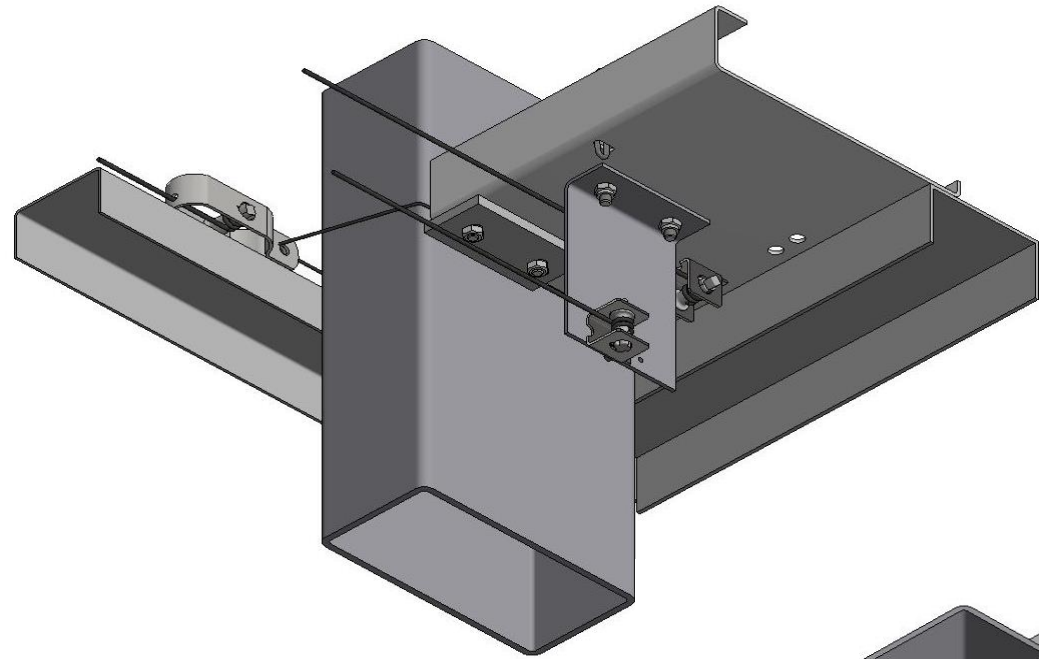
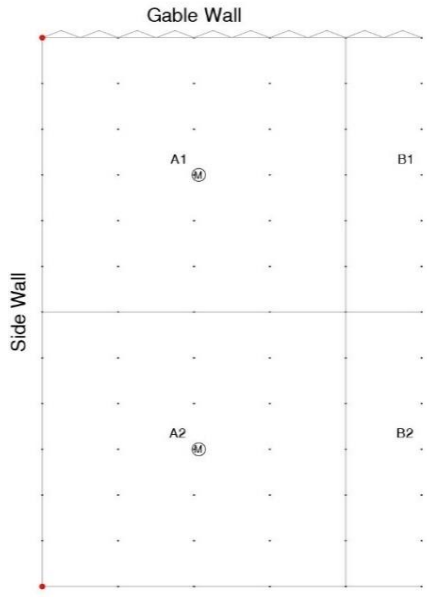

-  44.84.25
-  55.40.20 M8x20
-  55.40.05 M8
-  48.80.10
-  55.30.16 M6x16
-  55.30.00 M6
-  48.20.15
-  48.80.12

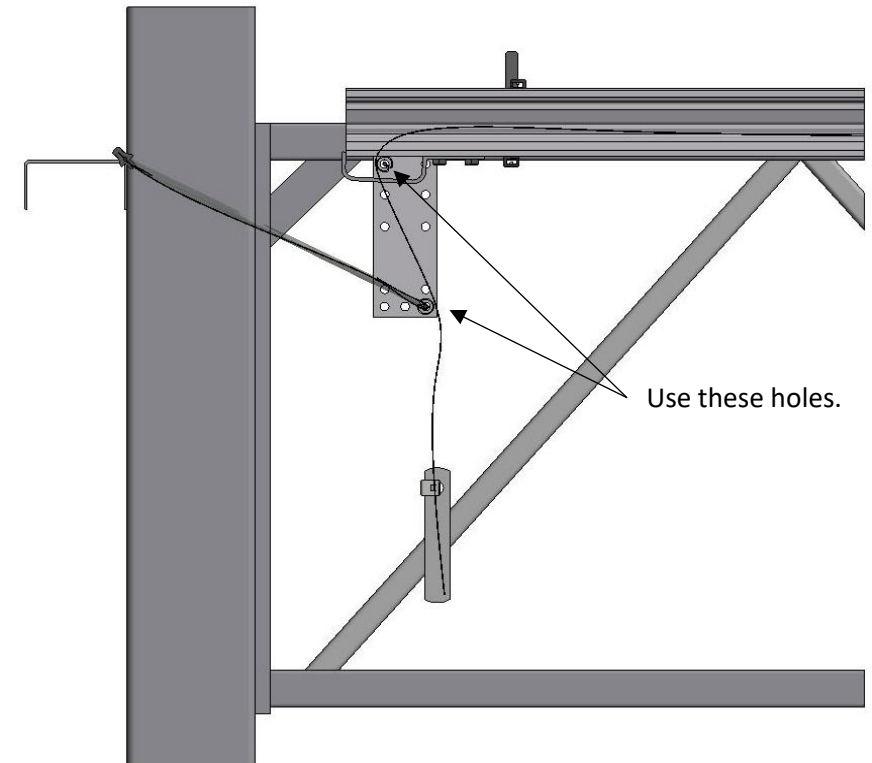
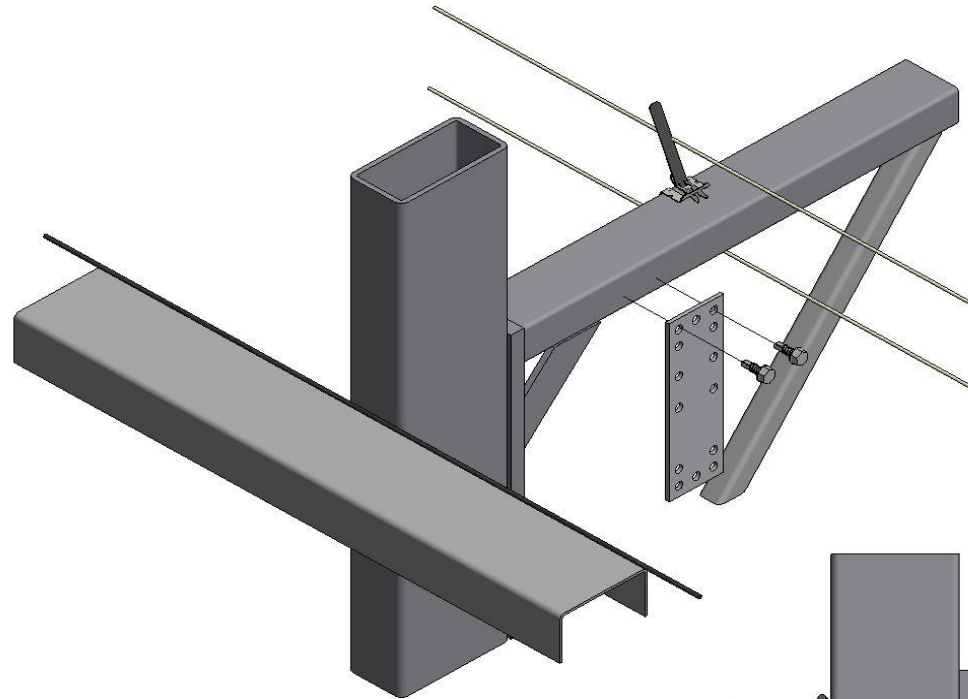
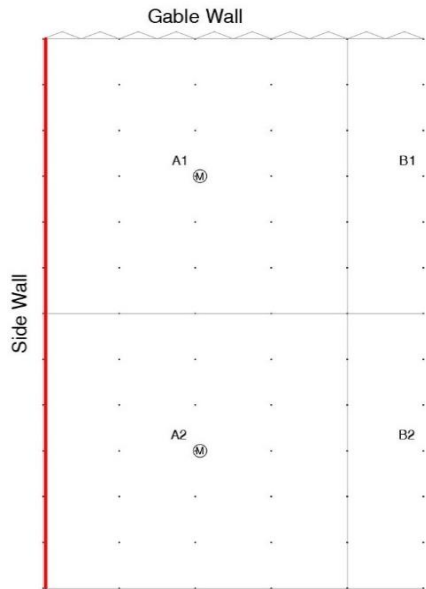

44.27.15



53.57.20

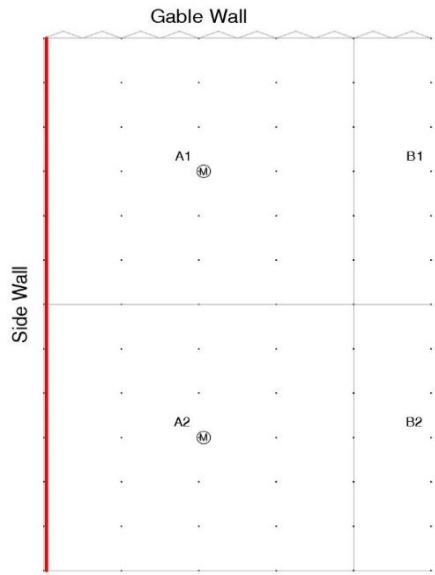

44.17.17 VSV 22

44.17.18 VSV 35



45.35.15

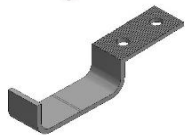

44.27.05



44.05.05



55.30.10



44.17.11

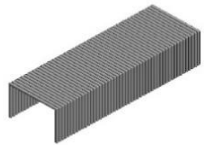
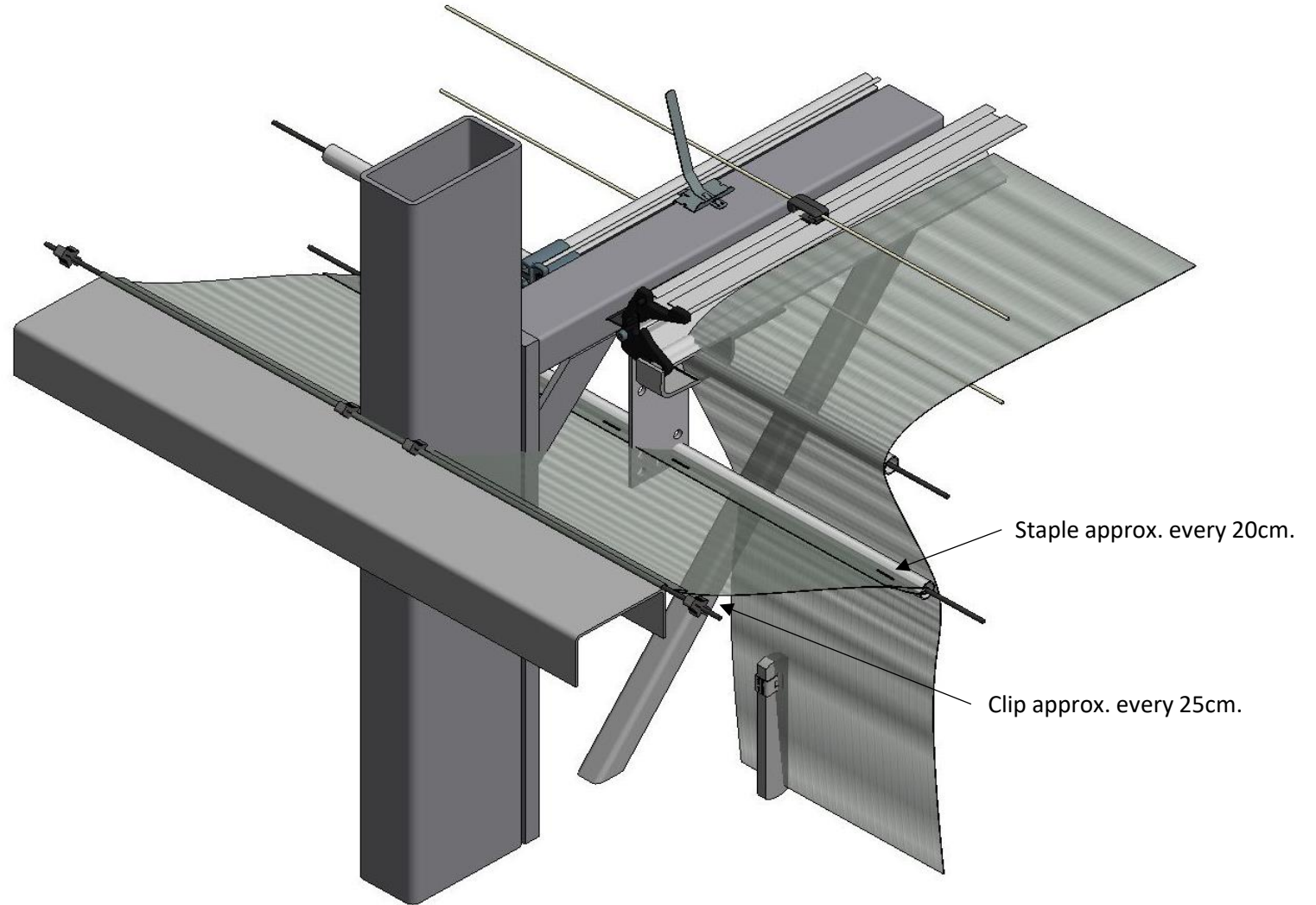
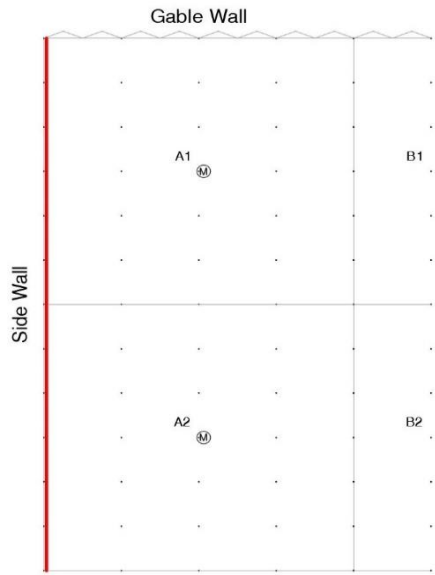

61.10.06



44.15.40



48.60.-----

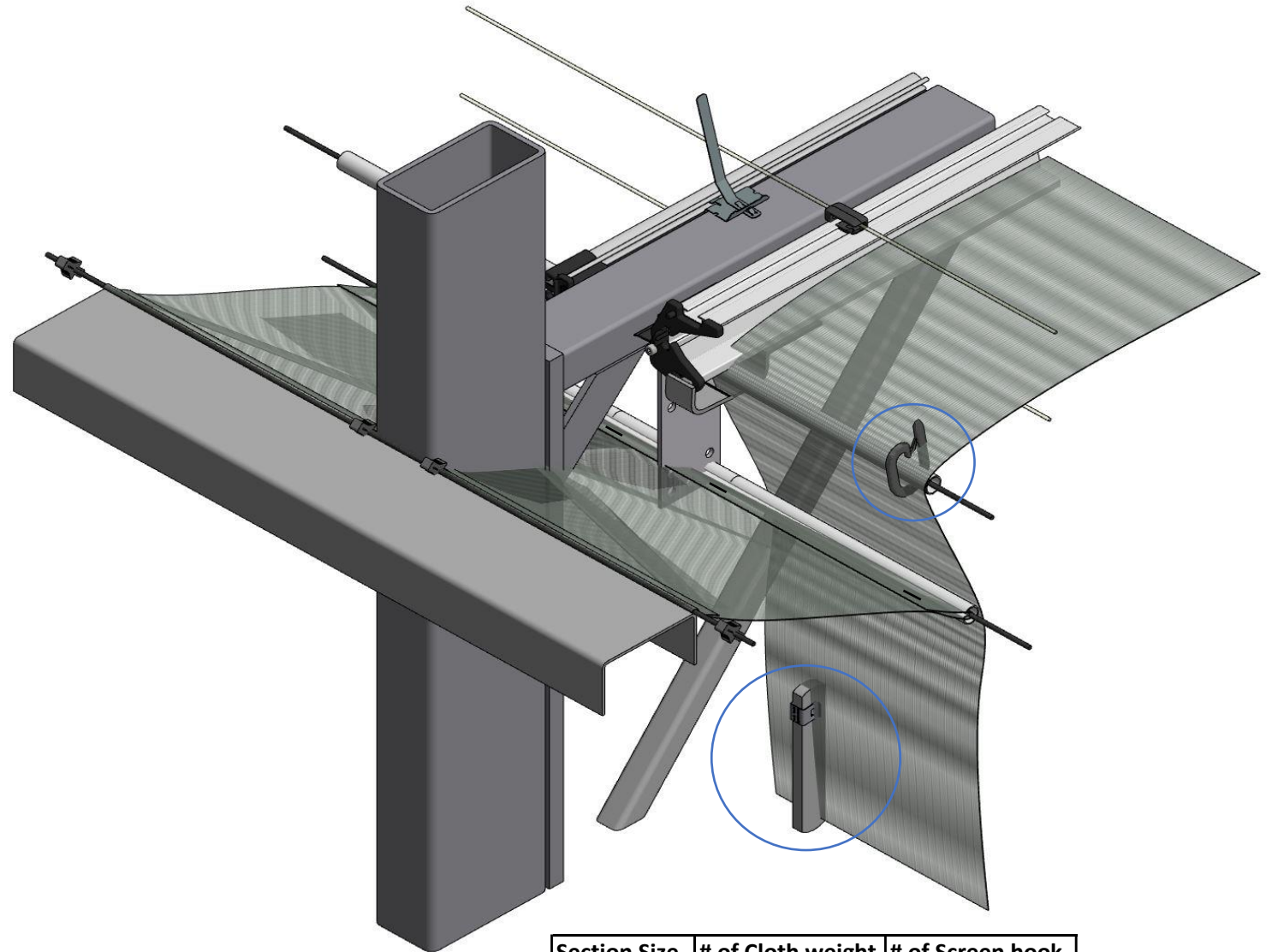
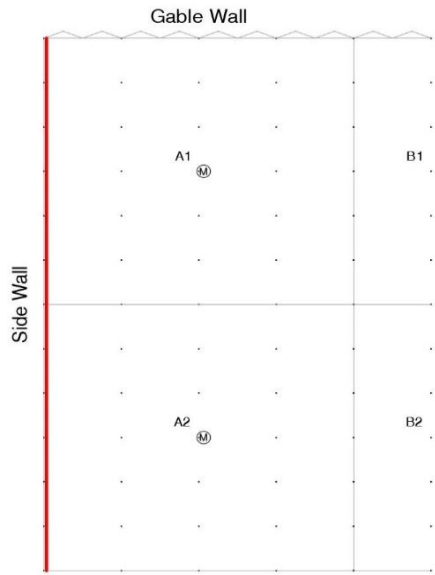

- 44.70.25
- 45.45.50
- 44.15.20

Section Size	# of Cloth weight	# of Screen hook
3658	5	7
4000	6	8
4500	7	9
5000	8	10